

# Kegelradgetriebe Bevel Gearboxes



[www.arcus-getriebe.de](http://www.arcus-getriebe.de)



**arcus**   
GETRIEBETECHNIK

MADE IN GERMANY



arcus Getriebetechnik  
Dipl. Ing. Dammenhayn  
Rissener Straße 140  
22880 Wedel

Telefon: +49 (0) 4103 / 90 006 - 20  
Telefax: +49 (0) 4103 / 90 006 - 26  
Mobil: +49 (0) 172 / 460 4500  
E-Mail: [gd@arcus-getriebe.de](mailto:gd@arcus-getriebe.de)  
[www.arcus-getriebe.de](http://www.arcus-getriebe.de)

24 hours-Hotline:  
**+49 (0) 4103 / 90 006 - 12**

Neue Leistung in klassischem Design	New performance in classical design	4 / 5
Produktbeschreibung	Product description	6 / 7
Projektiertung	Engineering	8 / 11
Formeln der Antriebstechnik	Formulars of drive system	12 / 13
Bestimmung der Getriebegröße	Definition of gear size	14
Wellenbelastungen	Shaft loading	15
Leistungen/ Drehmomente	Power ratings/ Torque ratings	16 / 17
Massenträgheitsmomente	Moment of inertia	18 / 19
Getriebegeichte	Gearbox weights	19
Schmierstoffviskosität/ Entlüftung	Lubricant viscosity/ Ventilation	20
Lage der Entlüftung	Position of vent filter	21
Schmierstofftabelle	Lubrication table	22
Bestellschlüssel	Order key	23
Bauarten- fliegend gelagerte Welle	Models- solid shaft with single bearings	24
Bauarten- Vollwelle	Models- solid shaft	25
Bauarten- Hohlwelle mit Schrumpfscheibe/	Models- hollow shaft with shrunk-on disk/	
Hohlwelle	Hollow shaft	26
Bauarten- Ritzelwelle	Models- pinion shaft	27
Abmessungen Typ F/ Typ FL	Dimensions type F/ type FL	28 / 29
Abmessungen Typ V/ Typ VL	Dimensions type V/ type VL	30 / 31
Abmessungen Typ H/ Typ HL	Dimensions type H/ type HL	32 / 33
Abmessungen Typ S/ Typ SL	Dimensions type S/ type SL	34 / 35
Abmessungen Typ R/ Typ RL	Dimensions type R/ type RL	36 / 37
Übertragbare Kupplungsdrehmomente	Transferrable coupling torque	38
Flansche für IEC- Normmotoren	Flange for IEC- standard motors	39
Flansche für Servo Motoren	Flanges for servo motors	40 / 41
Gewährleistung/ Qualitätskontrolle	Warranty/ Quality control	42/43

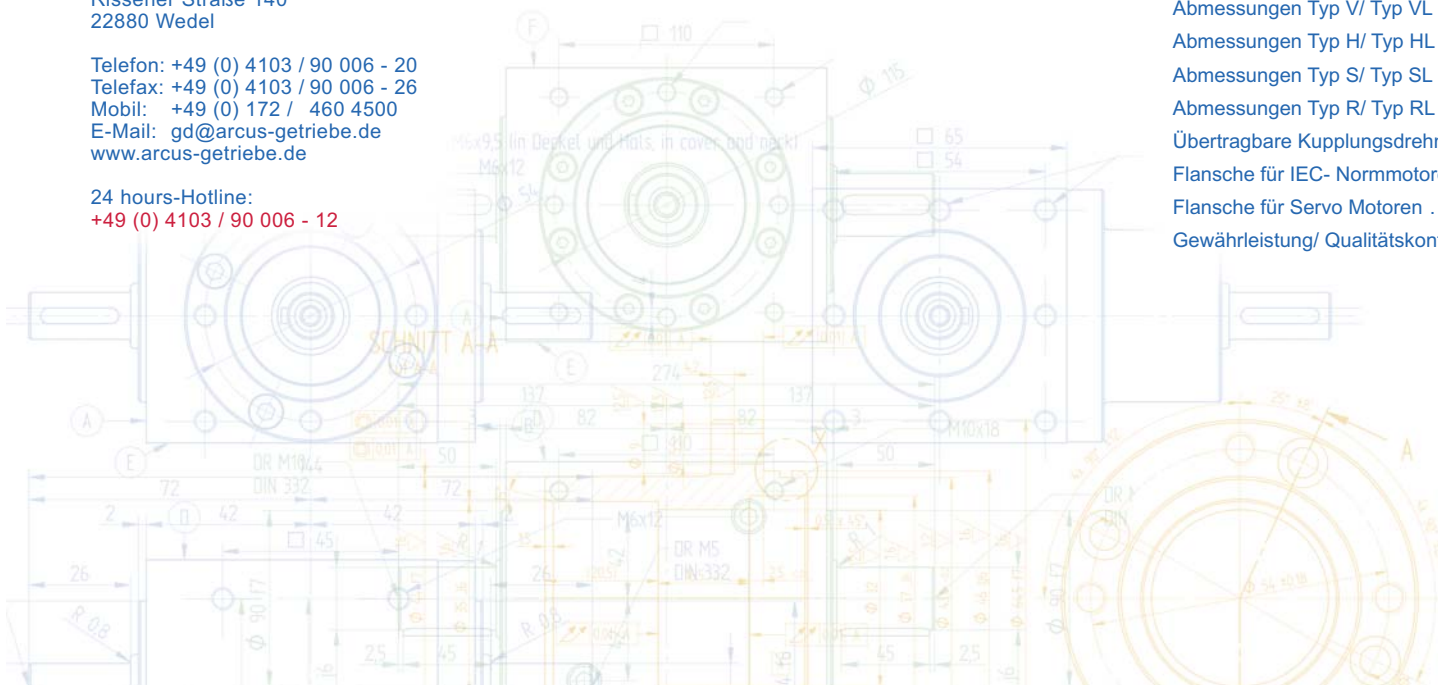

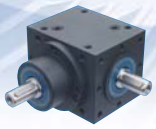

## Neue Leistung in klassischem Design

Einstufige Kegelradgetriebe der klassischen Bauform sind in ihrer Vielseitigkeit und Flexibilität durch kein anderes Getriebe ersetzbar.

arcus Getriebetechnik hat die einstufigen Kegelradgetriebe vollständig überarbeitet. Im Ergebnis stehen Drehmomentsteigerungen mit dem Faktor 2 und eine bisher nicht erzielte Universalität und Anwenderfreundlichkeit.



Dauerbetrieb oder hochdynamischen Zyklusbetrieb eingesetzt werden. Servomotoren, aber auch alle Drehstrommotoren werden über spielarme Kuppelungen mit integriertem Längenausgleich und ein umfangreiches Flanschsystem mit dem Präzisionsgetriebe verbunden.

Kegelradgetriebe von arcus Getriebe bieten größtmögliche Vielfalt in der Wahl der Bauform und der Gestaltung aller Anschlussverbindungen. Über den Wellenanschlüssen hat der Anwender die Wahl zwischen einer Befestigung im Teilkreis oder im Quadrat. Alle im Quadrat angeordneten Bohrbilder haben den Vorteil einer direkten Verschraubung mit dem Basisgehäuse.

Steigen die Anforderungen in Bezug auf die Getriebedrehzahl, ist der daraus folgende Temperaturanstieg kein Problem. Alle Kegelradgetriebe mit zwei und drei Wellen verfügen an den Seiten D, E und F über zwei diagonal angeordnete Verschlusschrauben, um bei erhöhtem Temperaturanstieg eine ideal positionierte Entlüftung einzusetzen.

In einem kompakten und äußerst robusten Gehäuse werden enorm hohe Leistungen ohne merkliche Wirkungsgradverluste in einem 90° Winkel umgelenkt oder auf bis zu fünf Abtriebswellen verteilt. Die Vielseitigkeit des neuen Gehäuses und seine hohe Fertigungsgenauigkeit ermöglichen eine problemlose Getriebeverketzung zur effizienten und kostengünstigen Leistungsverteilung.

Für ein großes Leistungsspektrum stehen dem Anwender spiralverzahnte Kegelradsätze mit Über- / Untersetzungen von 1:1 bis 6:1 zur Verfügung. Ihre hohe Präzision und eine verminderte Schnittstellenzahl innerhalb des Gehäuses erlauben die Herstellung von spielarmen Präzisionsgetrieben. Darüber hinaus bietet das verbesserte Lagersystem des Getriebebaukastens eine einsatzorientierte Auswahlmöglichkeit zwischen Kegelrollenlagern und Rillenkugellagern, deren Vor- und Nachteile wir gern mit Ihnen abstimmen.

In der Kombination mit Servomotoren entfalten die Getriebe ihre ganze Leistungsfähigkeit. Dabei spielt es keine Rolle, ob die Getriebe im hochtourigen

Mit der Reduzierung der Teilevielfalt können alle Standardkomponenten in wirtschaftlichen Losgrößen fertig bearbeitet eingelagert werden. Die auf-



tragsbezogene Montage erfolgt innerhalb kurzer Zeit. Um Lieferzeiten noch weiter zu reduzieren, werden viele Grundbauformen bereits versandfertig eingelagert. So können unsere Kunden arcus Getriebe innerhalb von 24 Stunden beziehen.

## New performance in classical design

Single-stage bevel gear boxes in classical design cannot be substituted by other gearboxes due to their universality and flexibility.

arcus Getriebetechnik has fully re-designed the single-stage bevel gear box. The results are torque increases up to a factor of 2, and a never before achieved level of universality and user friendliness. Enormously high performances are forwarded into a 90° angle or are allocated into up to five output shafts without a noticeable loss of efficiency within a compact designed and extremely robust housing. The universality of the new housing and its high manufacturing precision enable mechanical gear box chaining for the purpose of efficient and cost-effective mechanical performance distribution.



The user has access to a large range of performance availabilities for spiral toothed bevel gear sets with gear transmission ratios ranging from 1:1 to 6:1. Its high precision and reduced number of interfaces within the housing enables the manufacture of zero-play precision gear boxes. Furthermore, the improved system of bearings within the gear box housing offers the application-orientated selection of opportunities ranging from taper roller bearings to grooved ball bearings, whose advantages and disadvantages we would readily like to consult with you.

The gear box unfolds its full performance capability in combination with servo-motors. In the course, it does not matter if the gear box operates in a high-rotating speed continuous mode or in a highly dynamic cyclical mode. Servo-motors, and also all three-phase motors, are connected to the precision gear box via zero-play clutches with integrated length compensation and via a comprehensive flange system.

Bevel gear boxes made by arcus Getriebe offer the greatest possible variety in the choice of design forms, and in the design of all interface connections. The user possesses choice of connection in a diameter or square type arrangement via the shaft connections. All bore designs, arranged in a square, possess the advantage of direct fitting to the main housing.

If requirements increase with regard to the gear box rotating speed, the thus unfolding temperature increase presents no problem. All bevel gear boxes with two or three shafts possess two diagonally arranged screw plugs on the sides D, E, and F in order to implement ideally positioned ventilation capabilities in the case of an enhanced temperature increase.

All standard components may be stocked in economical lot sizes and fully manufactured due to the reduction of part variety. Assembly, as contingent to contracting, is performed within a short time. Many basic design forms are already stocked for commissioning in order to further reduce delivery times. In this manner, our customers can purchase arcus gear boxes within a delivery time of 24 hours.



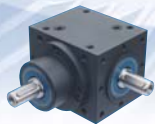

## Produktbeschreibung

	Standardausführung	Sonderausführung
<b>Gehäuse</b>	Kompaktes Präzisionsgehäuse mit minimierten Toleranzen und verringerter Schnittstellenzahl aus Grau- bzw. Sphäroguss	Sonderabmessungen, Gehäusekombinationen, Edelstahl, Aluminium
<b>Motorlaternen</b>	Gewichts- und variantensparende Aluminiumkonstruktion	Nach NEMA oder Kundenvorgaben
<b>Vollwellen Hohlwellen</b>	Passungstoleranz j6 bzw. H7 Vollwellenzentrierungen DIN 332/ 2 Passfederverbindungen DIN 6885/1 Passfedernut in Hohlwellen JS 9 Sicherungseinstich in Hohlwellen DIN 472 / 1 Rundlauf, Koaxialität, Planlauf DIN 42955 Werkstoff C45 / 42CrMo4	Sonderabmessungen, mit und ohne Passfedernut, profilierte Voll- und Hohlwellen nach DIN 5463, 5480 od. 5482, Trapezgewinde, alternative Werkstoffe wie z.B. Edelstahl und Bronze
<b>Kegelräder</b>	Spiralverzahnt nach Klingenberg Zyκλο- Palloid bzw. Gleason, gehärtet und geläppt, optimierte Zahngeometrie	Sonderübersetzungen, Endbearbeitung geschliffen
<b>Wellen- / Naben- verbindung</b>	Übersetzungsabhängige form-, kraft- bzw. stoffschlüssige Verbindungen	Ohne Welle-/Nabenverbindung aus dem Vollmaterial gefertigt
<b>Lagerung</b>	Je nach Belastung Kegelrollen- oder Rillenkugellager, oben liegende Lager abgedichtet und fettgeschmiert  Kegelrollenlager: <ul style="list-style-type: none"> <li>• für hohe Anforderungen an die Lagerlebensdauer</li> <li>• für hohe Lasten aus der Anschlussverbindung</li> </ul> Rillenkugellager: <ul style="list-style-type: none"> <li>• für hohe Drehzahlen</li> <li>• für niedrigere Schallpegel</li> <li>• für niedrigere Temperaturen durch geringere Rollreibung</li> </ul>	Zusätzliche Axiallagerung für Hubspindelbelastung, Lager mit erhöhter Tragfähigkeit
<b>Schmierung</b>	Synthetische Hochleistungsschmierstoffe ohne und mit Freigabe für den Lebensmittelpbereich nach NSF-H1, Füllmengen ab Werk der Einbaulage angepasst	Sonderschmierstoffe für besonders hohe oder tiefe Umgebungstemperaturen, biologisch abbaubare Schmierstoffe, Fettschmierung
<b>Entlüftung</b>	Ab Betriebstemperaturen > 50°C erforderlich, optional erhältliche Be- und EntlüftungsfILTER aus Kunststoff mit integriertem Ölabscheider, seitlicher Anbau über Rohrbogen	Filter im Metallgehäuse, Entlüftungsventile, Entlüftungsschrauben, Sonderentlüftungen
<b>Ölstandskontrolle</b>	Ölschauglas aus Kunststoff optional	Schauglas mit Metalleinfassung, externe Winkelölstandsanzeiger
<b>Gehäuse- abdichtung</b>	O- Ringdichtung, Spezialverschlussschrauben	Verschlussschrauben nach DIN 908
<b>Wellenabdichtung</b>	Radialwellendichtung mit optimierter Dichtlippengeometrie aus NBR, Viton oder PTFE, mit und ohne Staublippe. Oben liegende Dichtringe mit Spezialfett versehen Dichtringsitz drallfrei geschliffen	Sonderdichtungen für abrasive oder chemikalienbelastete Umgebungsmedien, Einsatz bei hohen Umgebungstemperaturen, unter Wasser, Überdruck oder Vakuum
<b>Oberflächen</b>	Wasserlösliche Grundierung oder galvanische Beschichtungen	Hochwertige 2K Industrielackierung in Wunschfarbe, Sonderfarbgebung
<b>Typenschild</b>	0,08 mm dickes Folienschild, sofern keine Angabe erfolgt an Seite E angebracht und von Seite D lesbar Nicht entfernen! = Garantieverlust	

## Product description

	Standard version	Custom version
<b>Housing</b>	Compact-design precision housing with minimized tolerances and a reduced number of interfaces made of gray and spheroidal graphite cast iron	Customized dimensions, housing combinations, stainless steel, aluminum
<b>Motor flange</b>	Weight and variant saving aluminum design	In accordance with NEMA or customer requirements
<b>Solid shafts Sleeve shafts</b>	Fit tolerance j6 and H7 Solid shaft centering spigot DIN 332/ 2 Parallel key connection DIN 6885/1 Parallel key slot in sleeve shafts JS 9 Safety plunge cut in sleeve shafts DIN 472 / 1 Concentric form, coaxial form, plane form Material DIN 42955 C45 / 42CrMo4	Customized dimensions, with and without parallel key slot, profile type solid and sleeve shafts in accordance with DIN 5463, 5480, or 5482, trapezoid-form screw thread, alternative materials such as stainless steel and bronze
<b>Bevel gears</b>	Spiral-toothed in accordance with Klingenberg cyclo- palloid design, and with Gleason, hardened and lapped, optimized tooth geometry	Customized transmission ratios, final grinding manufacture
<b>Shaft / Hub connection</b>	Transmission ratios are contingent to form-closed, force-closed, and material-type connection design	Without shaft / hub connection manufactured from full material
<b>Bearing</b>	Taper roller bearings or grooved ball bearings contingent to stress, overhead bearings sealed and greased Taper roller bearings: <ul style="list-style-type: none"> <li>• For high requirements placed on the bearing life-cycle</li> <li>• For high loads resulting from the interface connection</li> </ul> Grooved ball bearings: <ul style="list-style-type: none"> <li>• For high rotational speeds</li> <li>• For a low sound level</li> <li>• For low temperatures due to reduced rolling friction</li> </ul>	Additional axial bearing for lift spindle loading, bearing with enhanced loading capability
<b>Lubrication</b>	High-performance synthetic lubrication with and without approval for use in food environments in accordance with NSF-H1, filling volume adapted to the assembly position	Custom lubrication for especially high or low ambient temperatures, bio-degradable lubrication, grease lubrication
<b>Ventilation</b>	Required for operational temperatures > 50°C, Optionally available filters for aeration and deaeration made of plastic with an integrated oil separator Sideward assembly via pipe elbows	Filter assembled within the metal housing, deaeration valves, deaeration screws, custom ventilations
<b>Oil level control</b>	Optional oil inspection glass made of plastics	Inspection glass assembled into metal fixture, external display for slanted oil level
<b>Sealing of housing</b>	O-ring seal, custom screw plugs	Screw plugs in accordance with DIN 908
<b>Shaft sealing</b>	Radial shaft seal with optimized sealing lip geometry made of NBR, Viton, or PTFE, with and without dust lip. Overhead seal rings treated with special grease Seal ring fit ground free-of-twists	Custom seals for abrasive or chemically burdened environmental media, deployment for high ambient temperatures, under water operations, over-pressure or vacuum operations
<b>Surfaces</b>	Water solvent base layer, or galvanic layers	High-grade 2K industrial enamel, in a color at discretion Custom coloring
<b>Type plate</b>	0.08 mm thick foil plate, provided no information is positioned to side venue E, and such is visible from side venue D Do not remove! = Loss of guarantee	

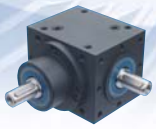

## Projektiertung (1)

<b>Einsatzmöglichkeiten</b>	Universeller Einsatz in allen Bereichen des Maschinen- und Anlagenbaus Extrem anpassungsfähiges Baukastensystem mit hoher Variantenvielfalt
<b>Orientierung</b>	Getriebeseiten werden mit den Buchstaben A bis F bezeichnet Definition: A = "Abtrieb", C = "Antrieb"
<b>Antrieb</b>	An jeder Welle möglich
<b>Lieferung mit Drehstrom-/ Servomotor</b>	Alle Getriebe können mit fertig montiertem Motor geliefert werden. Geben Sie uns hierzu Ihre Spezifikation auf und lassen Sie sich von uns beraten.
<b>Drehrichtung</b>	Rechts drehende Welle = beim Blick auf den Wellenspiegel dreht die Welle im Uhrzeigersinn Rechts drehende Ritzelwellen (K- Reihe = Seite C, KR- Reihe= Seite A) bewirken nach außen gerichtete Axialkräfte und reduzieren so den Schallpegel um bis zu 2 dB(A)
<b>Übersetzung</b>	<b>Typen V, H, S</b> Standardübersetzungen $i = n_1 / n_2 = 1:1 / 1,5:1 / 2:1 / 3:1 / 4:1 / 5:1 / 6:1$ für $i > 1,0$ gilt: <ul style="list-style-type: none"> <li>• Tellerrad an der Seite A: kleine Drehzahl + großes Drehmoment</li> <li>• Kegelritzel an Seite C: große Drehzahl + kleines Drehmoment</li> </ul> <b>Typ R</b> Standardübersetzungen $i = n_1 / n_2 = 1,5:1 / 2:1$ für $i > 1,0$ gilt: <ul style="list-style-type: none"> <li>• Kegelritzel an der Seite A: große Drehzahl + kleines Drehmoment</li> <li>• Tellerrad an Seite C: kleine Drehzahl + großes Drehmoment</li> </ul> Sonderübersetzungen und Übersetzungen $i > 6:1$ auf Anfrage
<b>Leistungsdaten</b>	Beziehen sich auf Anwendungsfaktor $K_A=1$ und 20.000 Betriebsstunden, normale Umgebungsbedingungen, optimale Schmierungsverhältnisse und einen Zahneingriff
<b>Leistungsdurchleitung</b>	Die Weiterleitung und Verteilung großer Leistungen sind mit Typ R besonders effektiv. Weil hier eine große Drehzahl und ein kleines Drehmoment transportiert werden, kann gegenüber anderen Typen eine kleinere, kostengünstigere Baugröße gewählt werden.
<b>Lagerauswahl</b>	Kegelrollenlager: <ul style="list-style-type: none"> <li>• für hohe Anforderungen an die Lagerlebensdauer</li> <li>• für hohe Lasten aus der Anschlussverbindung</li> </ul> Rillenkugellager: <ul style="list-style-type: none"> <li>• für hohe Drehzahlen</li> <li>• für niedrigere Schallpegel</li> <li>• für niedrigere Temperaturen durch geringere Rollreibung</li> </ul> Eine genaue Lagerbelastung kann nur unter Einbeziehung des Kraftangriffswinkels der äußeren Wellenlast ermittelt werden Sofern die Einbaulage es erlaubt, sollten die Lager im Ölbad laufen
<b>Flankenspiel</b>	an der Tellerradseite mit 2% vom Nennmoment: Standard= 10-15 Winkelminuten S1 < 10 Winkelminuten S2 < 6 Winkelminuten
<b>Wirkungsgrad</b>	>98 % bei Nennmoment und einem Zahneingriff Losbrechmomente auf Anfrage Optimierung durch: <ul style="list-style-type: none"> <li>• für <math>i &gt; 1:1</math> Tellerrad nicht unten anordnen (Planschverluste)</li> <li>• geringe Ölviskosität (sofern zulässig)</li> <li>• spezielle Dichtungen</li> </ul>

## Engineering (1)

<b>Possibilities of use</b>	Universal use in all areas of mechanical and plant engineering Extremely adaptable module system with a high level of variant variety
<b>Assembly orientation</b>	The gear box sides are defined with the letters A to F Definition: A = "Output", C = "Input"
<b>Drive</b>	Possible from every shaft
<b>Delivery with three-phase / servo motor</b>	All gear boxes may be delivered with a fully assembled motor. For this, please provide your specification, and receive consultation from us.
<b>Direction of rotation</b>	Right turning shaft = the shaft turns clockwise upon viewing the shaft end surface Right turning pinion shafts (K series = side C, KR series = side A) induce axial forces directed outwards, and thus reduce the sound level by up to 2 dB(A)
<b>Transmission ratio</b>	<b>Types V, H, S</b> Standard ratios $i = n_1 / n_2 = 1:1 / 1,5:1 / 2:1 / 3:1 / 4:1 / 5:1 / 6:1$ for $i > 1,0$ , the following applies: <ul style="list-style-type: none"> <li>• Crown wheel at side A: Low rotating speed + large torque</li> <li>• Bevel pinion at side C: Large rotating speed + low torque</li> </ul> <b>Type R</b> Standard ratios $i = n_1 / n_2 = 1,5:1 / 2:1$ for $i > 1,0$ , the following applies: <ul style="list-style-type: none"> <li>• Bevel pinion at side A: Large rotating speed + low torque</li> <li>• Crown wheel at side C: Low rotating speed + large torque</li> </ul> Special ratios and for ratios $i > 6:1$ , please place a request
<b>Performance data</b>	Relates to the application factor $K_A=1$ and 20,000 operational hours, Normal ambient conditions, optimal lubrication and a single tooth attack occurring
<b>Performance transmission</b>	The transmission and allocation of large performances are especially effective using Type R. As a large rotational speed and a small torque are transmitted, smaller and more cost-effective sizes can be selected compared to other types.
<b>Bearing selection</b>	Taper roller bearings: <ul style="list-style-type: none"> <li>• For high requirements placed on the bearing life-cycle</li> <li>• For high loads resulting from the interface connection</li> </ul> Grooved ball bearings: <ul style="list-style-type: none"> <li>• For high rotational speeds</li> <li>• For a low sound level</li> <li>• For low temperatures due to reduced rolling friction</li> </ul> The exact bearing load can only be determined by including the force attack angle of the outer shaft load. In as far as the assembly position permits, the bearing should operate in
<b>Flank clearance</b>	At the crown wheel side, deemed at 2% of nominal torque: standard case = 10 - 15 angle minutes S1 < 10 angle minutes S2 < 6 angle minutes
<b>Efficiency</b>	>98 % for nominal torque and a single tooth attack occurring Torque breakaway thresholds upon request Optimization resulting from: <ul style="list-style-type: none"> <li>• For <math>i &gt; 1:1</math>, do not position the crown wheel to the bottom (losses due to splashing)</li> <li>• Low oil viscosity (in as far as permitted)</li> <li>• Special seals</li> </ul>

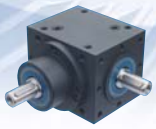

<b>Schallpegel</b>	70 – 85 dB(A) in 1m Entfernung Schallreduzierung durch: <ul style="list-style-type: none"> <li>• geringere Drehzahl</li> <li>• rechts drehende Ritzelwelle (Typen V, H, S = Seite C, Typ R = Seite A)</li> <li>• Verzicht auf Kegelrollenlager</li> <li>• hohe Ölviskosität</li> <li>• Entkopplung von Resonanzkörpern</li> </ul>
<b>Temperatur</b>	für Umgebungstemperatur -10 – 30°C, Große Leistungen in kleinen Getrieben können trotz ausgezeichneter Wirkungsgrade hohe Getriebetemperaturen bewirken. Zulässige Grenztemperatur mit Entlüftung ca. 90°C. Temperaturreduzierung durch: <ul style="list-style-type: none"> <li>• geringere Drehzahl</li> <li>• Getriebeentlüftung</li> <li>• geringe Ölviskosität</li> <li>• Tellerrad nicht/nur teilweise im Ölbad anordnen</li> <li>• gute Wärmeableitung</li> <li>• gesonderte Lüftung</li> </ul>
<b>Entlüftung</b>	Sind ab Baugröße K090 und einer Getriebetemperatur > 50°C erforderlich optional erhältlich und jederzeit nachrüstbar Je nach Bauart, Einbaulage, Drehzahl und Drehrichtung möglichst großen Abstand zum Radeingriff wählen Für eine ausreichende Frischluftzufuhr ist zu sorgen
<b>Befestigung</b>	Alle dargestellten Befestigungsmöglichkeiten sind im Standardgetriebe enthalten vorzugsweise Nutzung der im Quadrat angeordneten Befestigung, da diese eine direkte Verschraubung mit dem Basisgehäuse ermöglichen (ausgenommen K065 Seite B) Befestigung über 0,08 mm dickem Typenschild möglich
<b>Einbaulage</b>	Frei wählbar, zur optimalen Schmierstoffversorgung werden der Ölstand ab Werk angepasst und oben liegende Lager entsprechend mit Hochleistungsschmierfett versehen und abgedichtet
<b>Zentrierung</b>	Auf Wunsch ohne Grundierung Größere Zentrierdurchmesser sind optional lieferbar
<b>galvanisierte Gehäuse, Edelstahlgehäuse</b>	Galvanisierte Getriebegehäuse oder Edelstahlgehäuse sind mit verminderter Anzahl von Befestigungsbohrungen lieferbar Alle Wellen, Passfedern und Schrauben aus Edelstahl
<b>ATEX- Einsatz, Lagerzeit &gt; 6 Monate Überseetransporte, außergewöhnliche Einsatzbedingungen</b>	Bitte bei Bestellung angeben und Bedienungsanleitung beachten.
<b>Wartung</b>	Einmalige Kontrolle der Getriebetemperatur bei maximaler Belastung Getriebetemperatur >50°C Entlüftung (ab K090) einsetzen; >95°C Rücksprache Bei sehr hohen Anforderungen an die Standzeit oder Ausfallsicherheit: Ölwechsel nach ca. 500h, dann alle 15.000h Kontrolle auf Laufgeräusche, Ölverlust, Übertemperatur

<b>Sound level</b>	70 – 85 dB(A) at 1 meter distance Sound reduction resulting from: <ul style="list-style-type: none"> <li>• Low rotational speed</li> <li>• Right turning pinion shaft (types V, H, S = side C, type R = side A)</li> <li>• Waiver of taper roller bearings</li> <li>• High oil viscosity</li> <li>• De-coupling of resonance bodies</li> </ul>
<b>Temperature</b>	For ambient temperatures ranging -10°C to +30°C Large performances in small gear boxes may result in high gear box temperatures in spite of excellent performance efficiencies. Permissible limiting temperature including ventilation approx. 90°C Temperature reduction resulting from: <ul style="list-style-type: none"> <li>• Low rotational speed</li> <li>• Gear box de-aeration</li> <li>• Low oil viscosity</li> <li>• Do not / partly arrange crown wheel into oil bath</li> <li>• Good heat conduction</li> <li>• Extra use of ventilation</li> </ul>
<b>Ventilation</b>	Are necessary from sizes K090 and gear box temperatures > 50°C Available optionally, and may be re-fitted at any time Contingent to type, assembly position, rotational speed, and rotational direction, please select a greatest possible distance from location of wheel attack.
<b>Connection</b>	All displayed connection possibilities are included in the standard gear box Preferable deploy the connection arrangement in square form, as such enables direct bolting to the base housing (with exception to K065 side B) Attachment of a greater 0.08 mm thick type plate is possible Custom connection arrangements can be delivered on short term
<b>Assembly position</b>	Freely selectable; for optimal lubrication supply, the oil level is adapted ex-works, and overhead bearings are accordingly treated and sealed with high-performance sticky grease
<b>Centering</b>	Upon request, treated without a base layer Larger centering diameters may optionally be delivered
<b>Galvanized housing, stainless steel housing</b>	Galvanized gear box housings or stainless steel housings can be delivered with a reduced number of connection bores All shafts, parallel keys, and bolts made of stainless steel
<b>Use of ATEX, storage time &gt; 6 months Overseas transport, exceptional operational conditions</b>	Please indicate such upon ordering, and observe the operations manual.
<b>Maintenance</b>	One-time control of the gear box temperature at maximum loading; for a gear box temperature >50°C deploy ventilation (from K090); for > 95°C, request consultation For very high requirements placed on lifecycle time or security against down-time: Oil change after approx. 500 hours of operation, then every 15,000 hours Perform controls for operational sounds, oil loss, and over-temperature



# Formeln der Antriebstechnik Formulas of drive system

## Bewegungsgleichungen / equations of motion

	Translation / linear motion		Rotation / rotation	
	$v = \text{konst.}$	$a = \text{konst.}$	$\omega = \text{konst.}$	$\alpha = \text{konst.}$
<b>Weg / way</b>	$s = v \times t$	$s = \frac{v \times t}{2} = \frac{a \times t^2}{2} = \frac{v^2}{2 \times a}$	$\varphi = \omega \times t$	
<b>Zeit / time</b>	$t = \frac{s}{v}$	$t = \sqrt{\frac{2 \times s}{a}} = \frac{v}{a} = \frac{2 \times s}{v}$	$t = \frac{\varphi}{\omega}$	$t = \sqrt{\frac{2 \times \varphi}{\alpha}} = \frac{\omega}{\alpha} = \frac{2 \times \varphi}{\omega}$
<b>Geschwindigkeit / speed</b>	$v = \frac{s}{t}$	$v = \sqrt{2 \times a \times s} = \frac{2 \times s}{t} = a \times t$	$\omega = \frac{2 \times \pi \times n}{60}$	$\omega = \sqrt{2 \times a \times \varphi} = \frac{2 \times \varphi}{t} = \alpha \times t$
<b>Beschleunigung / acceleration</b>	$a = 0$	$a = \frac{v}{t} = \frac{2 \times s}{t^2} = \frac{v^2}{2 \times s}$	$\alpha = 0$	$\alpha = \frac{\omega}{t} = \frac{2 \times \varphi}{t^2} = \frac{\omega^2}{2 \times \varphi}$

## Umrechnung Rotation / Translation / conversion rotation / linear motion

<b>Winkel / angle</b>	$\varphi = \frac{2 \times 180}{\pi} \times \frac{s}{D}$	<b>Geschwindigkeit / speed</b>	$\omega = \frac{2 \times v}{D}$	$n = \frac{v \times 60}{\pi \times D}$	<b>Beschleunigung / acceleration</b>	$\alpha = \frac{2 \times a}{D}$
-----------------------	---	--------------------------------	---------------------------------	--	--------------------------------------	---------------------------------

## Massenträgheitsmomente / moment of inertia

	Translation / linear motion	Rotation / rotation
	$J_{ma2} = 91,2 \times m \times \left[ \frac{v}{n_2} \right]^2$	$J_{ma2} = \frac{1}{2} \times m \times r^2$ Vollzylinder / solid cylinder
		$J_{ma2} = \frac{1}{2} \times m \times (r_1^2 + r_2^2)$ Hohlzylinder / hollow cylinder
		$\sum J_{L2} = \sum J_{ma2} + J_{mot2} + J_{getr2} + \dots + J_n$
		$J_{mot2} = J_{mot1} \times i_{ges}^2$
		$J_{getr2} = J_{getr1} \times i_{ges}^2$
		$J_{mot1}$ Herstellerkatalog im Entwurf frei gewählt oder vernachlässigt
		$J_{getr1}$ manufacturer catalogue in project freely selected or neglected

## Statische Widerstandskräfte / static resisting power

	Haftreibung und Gleitreibung / adhesion and dynamic friction	
<b>Reibkraft / friction force</b>	$F_R = \mu \times F_N$	<b>Rollreibung / rolling friction</b> $F_R = m \times g \times \frac{2 \times f}{D}$
<b>Gewichtskraft / weight force</b>	$F_N = m \times g \times \cos \beta$	<b>Lagerreibung / bearing friction</b> $F_R = m \times g \times \mu_{La} \times \frac{d}{D}$
<b>Fahrwiderstand / driving resistance</b>	$F_f = m \times g \times \left[ \frac{2}{D} \times \left[ \mu_{La} \frac{d}{2} + f \right] + c \right]$	<b>Spurreibung / trace friction</b> $F_R = m \times g \times c$
	<b>Gravitationskräfte / adhesion and dynamic friction</b>	
<b>senkrecht Hubwerk / vertical lifting unit</b>	$F = m \times g$	<b>Hangabtriebskraft / gravity forces on batter</b> $F = m \times g \times \sin \beta$

## Dynamische Widerstandskräfte / dynamic resisting power

	Translation / linear motion	Rotation / rotation
<b>Beschleunigung / acceleration</b>	$F_B = m \times a$	$M_{2B} = \sum J_2 \times \alpha_2$

# Formeln der Antriebstechnik Formulas of drive system

## Drehmomente / torque

	Translation / linear motion	Rotation / rotation
	$M_2 = \frac{F \times D}{2}$	$M_2 = \sum J_{L2} \times \alpha_2 = \sum J_{L2} \times \frac{n_2}{9,55 \times t_B}$

## Leistung / output

	Translation / linear motion	Rotation / rotation
	$P_2 = \frac{F \times v}{1000}$	$P_2 = M_2 \times \omega = \frac{M_2 \times n_2}{9550}$

## Übersetzung / transmission

	$i = \frac{n_1}{n_2} = i_1 \times i_2 \times i_3 \times \dots \times i_n$	
--	---	--

## Wirkungsgrad / efficiency

	$\eta = \frac{T_2 \times 100}{T_1} = \frac{P_2 \times 100}{P_1}$	Der statische und dynamische Wirkungsgrad unterscheidet sich und ist getrennt zu betrachten. $\eta_{getr}$ bezieht sich auf das Nennmoment.
		The static and dynamic efficiency differ from each other and have to be considered separately. $\eta_{getr}$ applies to nominal torque.

## Formelzeichen / formula symbol

Formelzeichen / formula symbol				Indizes / index	
D	m	Durchmesser Rad / Scheibe ...	wheel / disc ...	B	Beschleunigung / Verzögerung
ED	%	Einschaltdauer	operating time	F	Fahr
F	N	Kraft	output	N	Nennbetrieb, Normale
J	kgm <sup>2</sup>	Massenträgheitsmoment	mass moment of inertia	R	Reibung
M	Nm	Drehmoment Arbeitsmaschine	torque work machine	L	Last
P	kW	Leistung	power	La	Lager
T	Nm	Drehmoment Getriebe	torque gearbox	ges	gesamt
a	m/s <sup>2</sup>	Beschleunigung	acceleration	getr	Getriebe
c		Spurkranz- und Seitenreibwert	flange- and side adhesion factor	n	alle wirksamen Faktoren
c <sub>1</sub>		Faktor Stoßbelastung	application factor	ma	Arbeitsmaschine
c <sub>2</sub>		Faktor Anlaufverhalten	attempt characteristics factor	max	maximal
c <sub>3</sub>		Faktor Umgebungstemperatur	ambient temperature factor	mot	Motor
c <sub>4</sub>		Faktor Einschaltdauer	operating time factor	m	mechanisch
d	mm	Zapfendurchmesser	shaft diameter	t	thermisch
f	mm	Hebelarm der Rollreibung	lever arm of rolling friction		
g	m/s <sup>2</sup>	Fallbeschleunigung (9,81)	gravitational acceleration (9,81)	1	schnell drehende Welle
i		Übersetzung	transmission ratio	2	langsam drehende Welle
m	kg	bewegte Masse	inertia		
n	min <sup>-1</sup>	Drehzahl	rotation speed		
r	m	Radius	radius		
s	m	Weg	stroke		
t	s	Zeit	time		
v	m/s	Geschwindigkeit	speed		
α	s <sup>-2</sup>	Winkelbeschleunigung	angular acceleration		
β	°	Neigungswinkel	angle of inclination		
φ	°	Winkelweg	angle path / stroke		
η	%	Wirkungsgrad	efficiency		
μ		Reibungszahl	coefficient of friction		
ω	s <sup>-1</sup>	Winkelgeschwindigkeit	angle speed		
Σ		Summe	sum		



# Bestimmung der Getriebegröße Definition of gear size

Erforderliche Leistung / Drehmoment des Getriebes / required output / torque of gearbox

Die zulässige mechanische Tragfähigkeit der Verzahnung kann bei Dauerbetrieb und fehlender Kühlung zu einer unzulässigen Getriebetemperatur oberhalb 95 °C führen. Um dies zu vermeiden, darf bei Dauerbetrieb die thermische Grenzleistung nicht überschritten werden.

The allowable mechanical load-carrying capacity can reach temperatures above 95 °C if the gearbox operates continuously without adequate cooling. To prevent overheating under continuous operation the thermal break-even performance should not be exceeded.

## Grenzwerte / limit values

mechanischer Grenzwert für das Drehmoment / mechanical threshold for torques		thermischer Grenzwert für die Leistung bei 100% Einschaltdauer / thermal threshold for the power with 100% operating time	
$M_{2m} = M_2 \times c_1 \times c_2$		$P_1 = P_1 \times c_3 \times c_4$	
$T_{2N} > M_{2m}$ $T_{2N}$ Leistungstabelle / power table		$P_{1N1} > P_1$ $P_{1N1}$ Leistungstabelle / power table	
$T_{2max} > M_{2max}$ $T_{2max}$ Leistungstabelle / power table			

Die Getriebe sind für gleichmäßige Belastungen und geringe Schaltfrequenz ausgelegt. Für abweichende Einsatzbedingungen sind nachfolgende Korrekturfaktoren notwendig

The gearboxes are designed for balanced operation with marginal switching frequency. For deviant operation condition subsequent correction factors are essential.

## Faktoren / factors

c <sub>1</sub> Faktor Stoßbelastung (Betriebsfaktor) / c <sub>1</sub> application factor				
	Arbeitsweise der getriebenen Maschine / working condition of the driven machine			
Arbeitsweise der Maschine / working condition of the driving machine	gleichmäßig / uniform	leichte Stöße / moderate impact	mäßige Stöße / medium impact	starke Stöße / heavy impact
gleichmäßig / uniform	1,00	1,25	1,50	1,75
leichte Stöße / moderate impact	1,10	1,35	1,60	1,85
mäßige Stöße / medium impact	1,25	1,50	1,75	2,00
starke Stöße / heavy impact	1,50	1,75	2,00	2,25
	Anwendungsfaktor nach DIN 3390 / ISO 6336 application factor according to DIN 3390 / ISO 6336			

c <sub>2</sub> Faktor Anlaufverhalten / c <sub>2</sub> attempt characteristics factor					
Anläufe je Stunde / startups per hour	bis / up to 10	10 - 59	60 - 199	200 - 499	500 - 800
Faktor c <sub>2</sub> / factor c <sub>2</sub>	1,00	1,10	1,20	1,30	1,60

c <sub>3</sub> Faktor Umgebungstemperatur / c <sub>3</sub> ambient temperature factor					
Umgebungstemperatur (°C) ambient temperature (°C)	10	20	30	40	50
Faktor c <sub>3</sub> / factor c <sub>3</sub>	0,90	1,00	1,10	1,25	1,50

c <sub>4</sub> Faktor Einschaltdauer / c <sub>4</sub> operating time factor					
Einschaltdauer (%) operating time (%)	100	80	60	40	20
Faktor c <sub>4</sub> / factor c <sub>4</sub>	1,00	0,83	0,71	0,62	0,55

# Wellenbelastungen Shaft loading

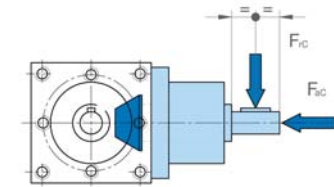
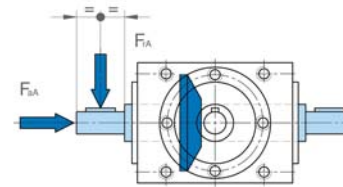

		Getriebegröße / gearbox size													
		F <sub>Rc</sub> [N] zulässige Radialbelastung / Permissible radial load						F <sub>Rc</sub> [N] zulässige Radialbelastung / Permissible radial load							
Antriebswelle Seite C / Inputshaft side C	n <sub>1</sub> [min <sup>-1</sup> ] n <sub>1</sub> [rpm]	T <sub>N</sub> = 50% Rillenkugellagern / roller bearing						T <sub>N</sub> = 100% Kegelrollenlager / tapered roller bearing							
		065	090	120	140	160	200	260	065	090	120	140	160	200	260
	50	600	1410	1530	2020	*	*	*	900	1750	2450	3400	3800	7100	14000
	250	390	1160	1380	1810				780	1730	2350	3280	3750	6600	12000
	500	320	960	1140	1550				660	1610	2240	3180	3650	6200	9800
	1000	300	560	960	1320				520	1510	2150	2860	3500	5700	7500
	1500	250	350	760	1060				390	1380	1970	2580	3300	5400	6500
	2000	220	310	630	920				310	1270	1910	2280	3200	5100	*
3000	190	210	530	720				260	1150	1820	2060	3000	4500		

		F <sub>Ac</sub> [N] zulässige Axialbelastung / Permissible axial load													
		T <sub>N</sub> = 50% Rillenkugellagern / roller bearing						T <sub>N</sub> = 100% Kegelrollenlager / tapered roller bearing							
Antriebswelle Seite C / Inputshaft side C	n <sub>1</sub> [min <sup>-1</sup> ] n <sub>1</sub> [rpm]	065	090	120	140	160	200	260	065	090	120	140	160	200	260
		50	390	900	980	1300	*	*	*	570	1100	1500	2210	2450	4600
	250	250	740	890	1200				500	1100	1480	2100	2400	4250	7800
	500	200	630	730	1000				410	1000	1430	2000	2350	4000	6330
	1000	190	360	630	860				330	950	1350	1800	2250	3700	4850
	1500	160	230	500	690				250	860	1250	1620	2150	3480	4200
	2000	130	200	400	600				200	800	1200	1430	2080	3300	*
	3000	120	130	350	460				160	720	1100	1300	1950	2850	

		Getriebegröße / gearbox size													
		F <sub>Ra</sub> [N] zulässige Radialbelastung / Permissible radial load						F <sub>Ra</sub> [N] zulässige Radialbelastung / Permissible radial load							
Abtriebswelle Seite A,B / Outputshaft side A,B	n <sub>2</sub> [min <sup>-1</sup> ] n <sub>2</sub> [rpm]	T <sub>N</sub> = 50% Rillenkugellagern / roller bearing						T <sub>N</sub> = 100% Kegelrollenlager / tapered roller bearing							
		065	090	120	140	160	200	260	065	090	120	140	160	200	260
	50	1000	1650	1860	2070	*	*	*	1000	2020	3380	5760	7800	11000	16500
	250	880	1400	1680	1850				910	1840	3120	5210	6700	8000	14800
	500	770	1180	1360	1720				800	1680	2950	4460	5800	7100	12000
	1000	600	990	1180	1460				650	1360	2710	3700	5000	6000	9200
	1500	490	750	960	1100				530	1110	2490	2950	4100	4800	7000
	2000	360	680	750	850				400	920	2260	2400	3500	4100	*
3000	280	450	580	650				300	850	2060	2150	3000	3500		

		F <sub>Aa</sub> [N] zulässige Axialbelastung / Permissible axial load													
		T <sub>N</sub> = 50% Rillenkugellagern / roller bearing						T <sub>N</sub> = 100% Kegelrollenlager / tapered roller bearing							
Abtriebswelle Seite A,B / Outputshaft side A,B	n <sub>2</sub> [min <sup>-1</sup> ] n <sub>2</sub> [rpm]	065	090	120	140	160	200	260	065	090	120	140	160	200	260
		50	650	1050	1200	1300	*	*	*	650	1300	2200	3730	5050	7100
	250	560	900	1050	1200				580	1150	2000	3350	4300	5200	9500
	500	500	750	880	1100				500	1050	1900	2850	3700	4600	7800
	1000	390	640	770	950				420	880	1750	2400	3250	3900	5900
	1500	325	460	620	700				330	710	1600	1900	2600	3000	4500
	2000	240	440	480	550				250	600	1450	1550	2250	2600	*
	3000	180	300	360	420				185	550	1300	1400	1950	2200	

Bei Typ R / LR und kombinierten Belastungen bitten wir um Rücksprache.  
Please contact us for typ R / RL and combined load applications.

\* Auf Anfrage  
\* on application





## Leistungen/Drehmomente Power ratings/Torque ratings

Antriebs- drehzahl Input speed $n_1$ min <sup>-1</sup>	Abtriebs- drehzahl Output speed $n_2$ min <sup>-1</sup>	Größe / Size											
		K 065			K 090			K 120			K 140		
		P kW	T <sub>2N</sub> Nm	T <sub>2max</sub> Nm	P kW	T <sub>2N</sub> Nm	T <sub>2max</sub> Nm	P kW	T <sub>2N</sub> Nm	T <sub>2max</sub> Nm	P kW	T <sub>2N</sub> Nm	T <sub>2max</sub> Nm
<b>P<sub>1NI</sub></b>		<b>2,2</b>			<b>4,2</b>			<b>7,1</b>			<b>10,8</b>		
<b>i = 1,0</b>													
50	50	0,12	23	35	0,33	63	112	0,73	140	236	1,31	250	445
250	250	0,60	23	35	1,65	63	112	3,66	140	236	6,54	250	445
500	500	1,20	23	35	3,30	63	112	7,33	140	236	13,09	250	445
1000	1000	2,41	23	35	6,60	63	112	14,66	140	236	26,18	250	445
1500	1500	3,61	23	35	9,90	63	112	21,99	140	236	39,27	250	445
2000	2000	4,82	23	35	13,19	63	112	29,32	140	236	52,36	250	445
3000	3000	7,23	23	35	19,79	63	112	43,98	140	236	78,53	250	445
<b>i = 1,5</b>													
50	33	0,08	22	34	0,20	58	102	0,48	137	231	0,82	235	425
250	167	0,38	22	34	1,01	58	102	2,39	137	231	4,10	235	425
500	333	0,77	22	34	2,02	58	102	4,78	137	231	8,20	235	425
1000	667	1,54	22	34	4,05	58	102	9,56	137	231	16,40	235	425
1500	1000	2,30	22	34	6,07	58	102	14,35	137	231	24,61	235	425
2000	1333	3,07	22	34	8,10	58	102	19,13	137	231	32,81	235	425
3000	2000	4,61	22	34	12,15	58	102	28,69	137	231	49,21	235	425
<b>i = 2,0</b>													
50	25	0,05	21	32	0,14	55	92	0,35	132	213	0,58	220	375
250	125	0,27	21	32	0,72	55	92	1,73	132	213	2,88	220	375
500	250	0,55	21	32	1,44	55	92	3,46	132	213	5,76	220	375
1000	500	1,10	21	32	2,88	55	92	6,91	132	213	11,52	220	375
1500	750	1,65	21	32	4,32	55	92	10,37	132	213	17,28	220	375
2000	1000	2,20	21	32	5,76	55	92	13,82	132	213	23,04	220	375
3000	1500	3,30	21	32	8,64	55	92	20,73	132	213	34,55	220	375
<b>i = 3,0</b>													
50	17	0,03	18	27	0,08	45	75	0,20	115	185	0,33	190	320
250	83	0,16	18	27	0,39	45	75	1,00	115	185	1,66	190	320
500	167	0,31	18	27	0,79	45	75	2,01	115	185	3,32	190	320
1000	333	0,63	18	27	1,57	45	75	4,01	115	185	6,63	190	320
1500	500	0,94	18	27	2,36	45	75	6,02	115	185	9,95	190	320
2000	667	1,26	18	27	3,14	45	75	8,03	115	185	13,26	190	320
3000	1000	1,88	18	27	4,71	45	75	12,04	115	185	19,90	190	320
<b>i = 4,0</b>													
50	13	-	-	-	0,06	43	73	0,13	97	163	0,23	172	295
250	63	-	-	-	0,28	43	73	0,63	97	163	1,13	172	295
500	125	-	-	-	0,56	43	73	1,27	97	163	2,25	172	295
1000	250	-	-	-	1,13	43	73	2,54	97	163	4,50	172	295
1500	375	-	-	-	1,69	43	73	3,81	97	163	6,75	172	295
2000	500	-	-	-	2,25	43	73	5,08	97	163	9,01	172	295
3000	750	-	-	-	3,38	43	73	7,62	97	163	13,51	172	295
<b>i = 5,0</b>													
50	10	-	-	-	0,04	39	63	0,09	85	146	0,15	148	248
250	50	-	-	-	0,20	39	63	0,45	85	146	0,77	148	248
500	100	-	-	-	0,41	39	63	0,89	85	146	1,55	148	248
1000	200	-	-	-	0,82	39	63	1,78	85	146	3,10	148	248
1500	300	-	-	-	1,23	39	63	2,67	85	146	4,65	148	248
2000	400	-	-	-	1,63	39	63	3,56	85	146	6,20	148	248
3000	600	-	-	-	2,45	39	63	5,34	85	146	9,30	148	248
<b>i = 6,0</b>													
50	8	-	-	-	0,03	32	54	0,06	71	121	0,11	123	205
250	42	-	-	-	0,14	32	54	0,31	71	121	0,54	123	205
500	83	-	-	-	0,28	32	54	0,62	71	121	1,07	123	205
1000	167	-	-	-	0,56	32	54	1,24	71	121	2,15	123	205
1500	250	-	-	-	0,84	32	54	1,86	71	121	3,22	123	205
2000	333	-	-	-	1,12	32	54	2,48	71	121	4,29	123	205
3000	500	-	-	-	1,68	32	54	3,72	71	121	6,44	123	205

## Leistungen/Drehmomente Power ratings/Torque ratings

Antriebs- drehzahl Input speed $n_1$ min <sup>-1</sup>	Abtriebs- drehzahl Output speed $n_2$ min <sup>-1</sup>	Größe / Size								
		K 160			K 200			K 260		
		P kW	T <sub>2N</sub> Nm	T <sub>2max</sub> Nm	P kW	T <sub>2N</sub> Nm	T <sub>2max</sub> Nm	P kW	T <sub>2N</sub> Nm	T <sub>2max</sub> Nm
<b>P<sub>1NI</sub></b>		<b>16,8</b>			<b>27</b>			<b>46</b>		
<b>i = 1,0</b>										
50	50	2,09	400	680	4,03	770	1185	10,21	1950	2800
250	250	10,47	400	680	20,16	770	1185	51,05	1950	2800
500	500	20,94	400	680	40,31	770	1185	102,09	1950	2800
1000	1000	41,88	400	680	80,63	770	1185	204,19	1950	2800
1500	1500	62,83	400	680	120,94	770	1185	306,28	1950	2800
2000	2000	83,77	400	680	161,26	770	1185	408,38	1950	2800
3000	3000	125,65	400	680	-	-	-	-	-	-
<b>i = 1,5</b>										
50	33	1,33	380	650	2,67	765	1145	6,63	1900	2760
250	167	6,63	380	650	13,35	765	1145	33,16	1900	2760
500	333	13,26	380	650	26,70	765	1145	66,32	1900	2760
1000	667	26,53	380	650	53,40	765	1145	132,64	1900	2760
1500	1000	39,79	380	650	80,10	765	1145	198,95	1900	2760
2000	1333	53,05	380	650	106,81	765	1145	265,27	1900	2760
3000	2000	79,58	380	650	160,21	765	1145	397,91	1900	2760
<b>i = 2,0</b>										
50	25	0,96	365	630	1,94	740	1100	4,84	1850	2670
250	125	4,78	365	630	9,69	740	1100	24,21	1850	2670
500	250	9,55	365	630	19,37	740	1100	48,43	1850	2670
1000	500	19,11	365	630	38,74	740	1100	96,86	1850	2670
1500	750	28,66	365	630	58,12	740	1100	145,29	1850	2670
2000	1000	38,22	365	630	77,49	740	1100	193,72	1850	2670
3000	1500	57,33	365	630	116,23	740	1100	290,58	1850	2670
<b>i = 3,0</b>										
50	17	0,52	300	505	1,24	710	1060	2,88	1650	2800
250	83	2,62	300	505	6,20	710	1060	14,40	1650	2800
500	167	5,24	300	505	12,39	710	1060	28,80	1650	2800
1000	333	10,47	300	505	24,78	710	1060	57,59	1650	2800
1500	500	15,71	300	505	37,17	710	1060	86,39	1650	2800
2000	667	20,94	300	505	49,56	710	1060	115,18	1650	2800
3000	1000	31,41	300	505	74,35	710	1060	172,77	1650	2800
<b>i = 4,0</b>										
50	13	0,38	290	490	0,80	610	980	1,85	1410	2390
250	63	1,90	290	490	3,99	610	980	9,23	1410	2390
500	125	3,80	290	490	7,98	610	980	18,46	1410	2390
1000	250	7,59	290	490	15,97	610	980	36,91	1410	2390
1500	375	11,39	290	490	23,95	610	980	55,37	1410	2390
2000	500	15,18	290	490	31,94	610	980	73,82	1410	2390
3000	750	22,77	290	490	47,91	610	980	110,73	1410	2390
<b>i = 5,0</b>										
50	10	0,27	255	430	0,54	515	875	1,39	1330	2260
250	50	1,34	255	430	2,70	515	875	6,96	1330	2260
500	100	2,67	255	430	5,39	515	875	13,93	1330	2260
1000	200	5,34	255	430	10,79	515	875	27,85	1330	2260
1500	300	8,01	255	430	16,18	515	875	41,78	1330	

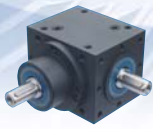

## Massenträgheitsmomente / Moments of inertia

## Massenträgheitsmomente / Moments of inertia Getriebegehäuse / Gearbox weights

Massenträgheitsmomente / Moment of Inertia, J (kg/cm <sup>2</sup> )													
Größe Size	$i = \frac{n_1}{n_2}$	Bauart / Model											
		Typ / Type F				Typ / Type V				Typ / Type H		Typ / Type S	
		A0	AB0	A1	AB1	A0 B0	AB0	A1 B1	AB1	AB0	AB1	A0 B0	A1 B1
065	1,0	0,5228	0,7842	0,7242	0,9657	0,5967	0,6018	0,8581	0,8631	0,5888	0,8502	0,6004	0,8618
	1,5	0,2387	0,3785	0,3288	0,4597	0,2723	0,2738	0,3712	0,3728	0,2681	0,3670	0,2732	0,3722
	2,0	0,1608	0,2511	0,2263	0,3116	0,1796	0,1806	0,2501	0,2511	0,1773	0,2478	0,1802	0,2507
	3,0	0,1187	0,1782	0,1758	0,2331	0,1271	0,1275	0,1864	0,1868	0,1261	0,1854	0,1274	0,1867
090	1,0	2,1483	3,2235	3,2215	4,2967	2,6630	2,6856	3,7362	3,7588	2,5887	3,6619	2,6735	3,7467
	1,5	1,2604	1,9630	1,8180	2,5207	1,4769	1,4855	2,0346	2,0431	1,4561	2,0138	1,4938	2,0514
	2,0	0,7759	1,2088	1,2495	1,6824	0,8978	0,9025	1,2408	1,2454	0,8860	1,2289	0,9072	1,2501
	3,0	0,5723	0,7939	0,9230	1,1446	0,6267	0,6286	0,9775	0,9793	0,6213	0,9720	0,6307	0,9814
	4,0	0,4800	0,6228	0,8172	0,9600	0,5097	0,5117	0,8469	0,8488	0,5075	0,8447	0,5128	0,8500
	5,0	0,4279	0,5248	0,7590	0,8559	0,4468	0,4482	0,7779	0,7792	0,4455	0,7766	0,4489	0,7800
120	1,0	10,8438	16,2657	16,2657	21,6877	13,4930	13,6072	18,9149	19,0291	13,1241	18,5460	13,2413	18,6632
	1,5	4,6252	7,4240	6,4516	9,2504	5,8198	5,8533	7,6461	7,6797	5,6386	7,4650	5,6907	7,5171
	2,0	3,0026	4,7382	4,2696	6,0052	3,6743	3,6934	4,9413	4,9604	3,5727	4,8396	3,6020	4,8689
	3,0	1,9620	2,8830	3,0030	3,9240	2,2623	2,2690	3,3033	3,3100	2,2154	3,2564	2,2284	3,2694
	4,0	1,5654	2,1371	2,5592	3,1308	1,7314	1,7381	2,7251	2,7319	1,7079	2,7017	1,7153	2,7090
	5,0	1,3683	1,7685	2,3364	2,7366	1,4743	1,4788	2,4425	2,4470	1,4595	2,4276	1,4642	2,4323
140	1,0	27,7304	41,5956	41,5955	55,4608	33,0778	33,3578	46,9429	47,2230	31,3777	45,2429	32,4009	46,2661
	1,5	13,9450	21,7111	20,1238	27,8899	16,3517	16,4461	22,5305	22,6248	15,5660	21,7448	16,0208	22,1996
	2,0	9,3912	14,1273	14,0462	18,7823	10,7422	10,7980	15,3972	15,4530	10,3030	14,9580	10,5588	15,2138
	3,0	6,6095	8,9746	10,8538	13,2189	7,2134	7,2347	11,4577	11,4791	7,0147	11,2591	7,1284	11,3728
	4,0	5,5951	7,0678	9,7174	11,1902	5,9237	5,9468	10,0460	10,0692	5,8231	9,9454	5,8870	10,0093
	5,0	5,0805	6,0880	9,1535	10,1610	5,2894	5,3056	9,3624	9,3786	5,2264	9,2994	5,2673	9,3403
160	1,0	47,1774	71,8512	71,8512	95,7776	55,9850	56,3081	73,5544	73,9987	54,3314	71,9296	54,8166	72,4095
	1,5	26,8567	40,9028	37,9119	50,5366	31,6558	31,8385	41,5902	41,8414	30,7208	40,6714	30,9952	40,9428
	2,0	22,1132	33,6784	31,2158	41,6107	23,6589	23,7954	31,0836	31,2714	22,9601	30,3970	23,1652	30,5998
	3,0	10,4532	15,9202	16,5889	22,1130	11,6894	11,7569	15,3578	15,4506	11,3441	15,0186	11,4455	15,1188
	4,0	8,6581	13,1863	13,7401	18,3156	9,9687	10,0262	13,0971	13,1762	9,6743	12,8078	9,7607	12,8932
	5,0	7,6518	11,6537	12,1431	16,1868	8,5234	8,5726	11,1982	11,2659	8,2716	10,9509	8,3455	11,0239
200	1,0	128,365	195,500	195,500	260,602	146,653	147,500	192,676	193,840	142,322	188,420	143,593	189,677
	1,5	86,6974	132,040	122,385	163,140	95,6215	96,1733	125,630	126,389	92,7971	122,855	93,6260	123,674
	2,0	44,2597	67,4075	62,4787	83,2841	41,7462	41,9871	54,8471	55,1784	40,5131	53,6356	40,8750	53,9934
	3,0	26,6581	40,6003	42,3055	56,3932	19,3284	19,4399	25,3941	25,5475	18,7575	24,8332	18,9250	24,9988
	4,0	21,3654	32,5395	33,9062	45,1969	24,3625	24,5031	32,0080	32,2013	23,6429	31,3010	23,8541	31,5098
	5,0	19,8963	30,3021	31,5748	42,0891	20,4718	20,5900	26,8964	27,0588	19,8672	26,3022	20,0446	26,4777
260	1,0	784,236	1194,39	1194,39	1592,12	872,327	877,361	1146,08	1153,01	846,561	1120,77	854,122	1128,24
	1,5	398,365	606,710	562,347	749,609	452,215	454,825	594,131	597,719	438,858	581,006	442,778	584,883
	2,0	239,452	364,685	338,020	450,580	226,687	227,995	297,827	299,626	219,991	291,248	221,956	293,191
	3,0	148,365	225,960	235,450	313,855	147,875	148,728	194,282	195,455	143,507	189,990	144,789	191,258
	4,0	108,986	165,986	172,957	230,552	117,318	117,995	154,136	155,067	113,853	150,731	114,870	151,736
	5,0	91,4523	139,282	145,132	193,461	95,2497	95,7994	125,141	125,897	92,4363	122,377	93,2619	123,193
6,0	83,6598	127,414	132,765	176,976	89,6497	90,1671	117,784	118,495	87,0017	115,182	87,7788	115,951	

Getriebegehäuse / Gearbox Weights, m (kg)												
Größe Size	Bauart / Model											
	Typ / Type F				Typ / Type V				Typ / Type H		Typ / Type S	
	A0	AB0	A1	AB1	A0 B0	AB0	A1 B1	AB1	AB0	AB1	A0 B0	A1 B1
065	2,3	2,8	2,8	3,3	2,4	2,5	2,9	3,0	2,4	2,9	2,6	3,1
090	5,3	6,5	6,5	7,9	5,7	5,8	6,9	6,9	5,5	6,7	5,8	6,8
120	11,7	14,4	14,3	17,6	13,2	13,4	16,2	16,0	12,5	15,3	12,7	15,4
140	18,2	22,4	22,2	27,4	19,6	20,2	24,1	24,3	18,5	22,8	19,1	23,4
160	30,0	36,0	36,0	42,0	29,5	30,0	36,0	36,5	28,0	34,0	29,0	35,0
200	53,5	61,5	63,5	71,0	50,5	52,5	61,0	63,0	50,5	58,5	52,0	60,0
260	90,0	111,0	109,5	135,0	92,0	93,5	96,0	118,0	86,0	111,0	89,0	113,5

Massenträgheitsmomente / Moment of Inertia, J (kg/cm <sup>2</sup> )					
Größe Size	$i = \frac{n_1}{n_2}$	Bauart / Model			
		Typ / Type R			
		A0 B0	AB0	A1 B1	AB1
090	1,5	1,0045	1,0194	1,7072	1,7221
	2,0	0,5846	0,5994	1,0175	1,0323
120	1,5	3,9817	4,0097	6,7805	6,8085
	2,0	2,3588	2,3869	4,0945	4,1225
140	1,5	10,6099	10,6230	18,3761	18,3891
	2,0	6,0561	6,0692	10,7923	10,8053
160	1,5	20,4689	20,5351	31,5242	30,1690
	2,0	10,9940	11,0700	20,0966	19,0023
200	1,5	55,3468	56,3486	91,0348	87,4482
	2,0	31,6492	32,9784	47,2966	48,8550
260	1,5	301,659	309,639	465,641	452,538
	2,0	146,650	151,630	245,217	237,524

Getriebegehäuse / Gearbox Weights, m (kg)				
Größe Size	Bauart / Model			
	Typ / Type R			
	A0 B0	AB0	A1 B1	AB1
090	5,1	5,2	6,5	6,6
120	11,5	11,6	14,8	14,9
140	17,3	17,4	22,4	22,5
160	28,5	29,0	34,5	35,0
200	51,0	52,0	59,0	60,0
260	85,0	86,5	108,0	109,5





# Schmierstoffviskosität, Entlüftung Lubricant viscosity, Ventilation

# Lage der Entlüftung Position of vent filter

Einschaltdauer / Operating Time 100 % / h

Drehzahl Speed n <sub>2</sub> [min <sup>-1</sup> ]	Baugröße / Size						
	K065	K090	K120	K140	K160	K200	K260
400	460	460	460	460	460	220	220
500	460	460	460	460	220	220	150
600	460	460	460	220	220	150	150
700	460	220	220	220	220	150	150
800	460	220	220	220	220	150	E 150
900	460	220	220	220	150	150	E 68
1000	460	220	220	150	150	E 150	E 68
1100	460	220	220	150	150	E 150	E 68
1200	460	220	150	150	150	E 68	E 68
1300	220	150	150	150	E 150	E 68	E 68
1400	220	150	150	150	E 150	E 68	E 68
1500	220	150	150	E 150	E 68	E 68	E 68
1600	220	150	150	E 150	E 68	E 68	E 68
1700	220	150	150	E 68	E 68	E 68	E 68
1800	220	150	150	E 68	E 68	E 68	E 68
1900	220	150	E 150	E 68	E 68	E 68	E 68
2000	220	150	E 150	E 68	E 68	E 68	E 68
2100	220	150	E 150	E 68	E 68	E 68	E 68
2200	220	150	E 68	E 68	E 68	E 68	E 68
2300	220	E 150	E 68	E 68	E 68	E 68	E 68
2400	220	E 150	E 68	E 68	E 68	E 68	E 68
2500	150	E 68	E 68	E 68	E 68	E 68	E 68
3000	150	E 68	E 68	E 68	E 68	E 68	E 68

Einschaltdauer / Operating Time 50 % / h

Drehzahl Speed n <sub>2</sub> [min <sup>-1</sup> ]	Baugröße / Size						
	K065	K090	K120	K140	K160	K200	K260
400	460	460	460	460	460	460	220
500	460	460	460	460	460	220	220
600	460	460	460	460	220	220	220
700	460	460	460	460	220	220	220
800	460	460	460	220	220	220	150
900	460	460	460	220	220	220	150
1000	460	460	220	220	220	150	150
1100	460	220	220	220	220	150	150
1200	460	220	220	220	220	150	150
1300	460	220	220	220	150	150	150
1400	460	220	220	220	150	150	150
1500	460	220	220	150	150	150	150
1600	460	220	220	150	150	150	68
1700	220	220	220	150	150	150	68
1800	220	220	150	150	150	68	68
1900	220	150	150	150	150	68	E 68
2000	220	150	150	150	150	68	E 68
2100	220	150	150	150	150	E 68	E 68
2200	220	150	150	150	68	E 68	E 68
2300	220	150	150	150	68	E 68	E 68
2400	220	150	150	150	E 68	E 68	E 68
2500	220	150	150	150	E 68	E 68	E 68
2600	220	150	150	68	E 68	E 68	E 68
2700	220	150	150	E 68	E 68	E 68	E 68
2800	220	150	150	E 68	E 68	E 68	E 68
2900	220	150	E 150	E 68	E 68	E 68	E 68
3000	220	150	E 68	E 68	E 68	E 68	E 68

E = mit Entlüftungsfiter / with Vent Filter

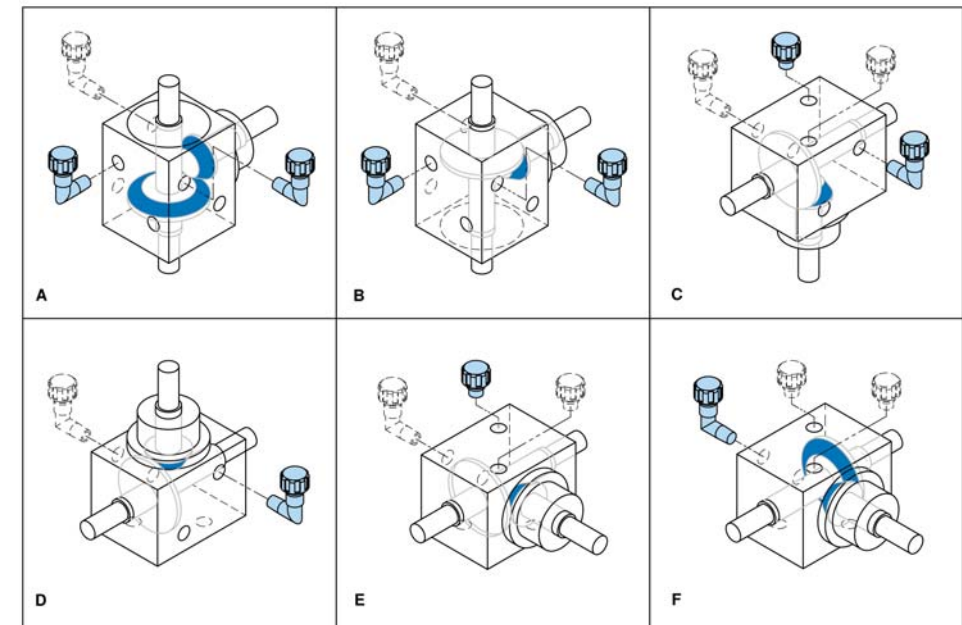
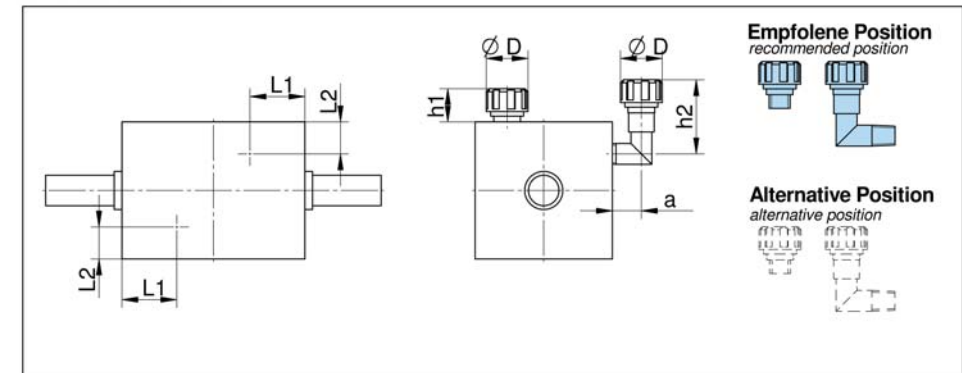

Größe Size	Gewinde Thread	a mm	D mm	h1 mm	h2 mm	L1 mm	L2 mm
090	1/4"	15	27	21	50	31	21
120	3/8"	15	32	25	55	36	24
140	3/8"	15	32	25	55	40	28
160	1/2"	15	32	25	59	52	37
200	1/2"	15	32	25	59	54	37
260	1/2"	15	32	25	59	62	40



Schmierstoff Lubricant	Kennzeichnung Designation	Viskosität mm <sup>2</sup> /s bei 40°C	ARAL	BEICHEM	bp	Castrol	LUBRITECH	KILBERER	Mobil	Optimal	Shell	Tribol
Synthetische Getriebeöle Synthetic gear oil (PAO) CLP-HC	ISO VG 460	414-506	Aral Degol PAS 320	BERUSYNTH GP 460	Energyn HTX 460	Alphasyn EP 460	GEARMASTER SYN 460	Küblersynth GEM 4-460N	Mobilgear SHC AMP 460	Optigear Synthetic A 460	Shell Omala HD 460	Tribol 1510/460
	ISO VG 320	288-352	Aral Degol PAS 220	BERUSYNTH GP 320	Energyn EP-XF 460	Optigear Synthetic X 460	GEARMASTER SYN 320	Küblersynth GEM 4-320N	Mobilgear SHC AMP 320	Optigear Synthetic A 320	Shell Omala HD 320	Tribol 1510/320
	ISO VG 220	198-242	Aral Degol PAS 220	BERUSYNTH GP 220	Energyn HTX 220	Optigear Synthetic X 220	GEARMASTER SYN 220	Küblersynth GEM 4-220N	Mobilgear SHC AMP 220	Optigear Synthetic A 220	Shell Omala HD 220	Tribol 1510/220
	ISO VG 150	135-165	Aral Degol PAS 150	BERUSYNTH GP 150	Energyn EP-XF 150	Optigear Synthetic X 150	GEARMASTER SYN 150	Küblersynth GEM 4-150N	Mobilgear SHC AMP 150	Optigear Synthetic A 150	Shell Omala HD 150	Tribol 1510/150
Synthetische Getriebeöle Synthetic gear oil (Polyalkyle) CLP-PG	ISO VG 460	414-506	Aral Degol GS 460	BERUSYNTH EP 460	BP Energyn SG-XP 460	Alphasyn PG 460	GEARMASTER PG 460	Küblersynth GH 6-460	Mobil Glygyle 460	Optiflex A 460	Shell Trelia S 460	Tribol 800/460
	ISO VG 220	198-242	Aral Degol GS 220	BERUSYNTH EP 220	BP Energyn SG-XP 220	Alphasyn PG 220	GEARMASTER PG 220	Küblersynth GH 6-220	Mobil Glygyle 220	Optiflex A 220	Shell Trelia S 220	Tribol 800/220
	ISO VG 150	135-165	Aral Degol GS 150	BERUSYNTH EP 150	BP Energyn SG-XP 150	Alphasyn PG 150	GEARMASTER PG 150	Küblersynth GH 6-150	Mobil Glygyle 150	Optiflex A 150	Shell Trelia S 150	Tribol 800/150
	ISO VG 100	90-110	Aral Degol GS 100	BERUSYNTH EP 100	BP Energyn SG-XP 100	Alphasyn PG 100	GEARMASTER PG 100	Küblersynth GH 6-100	Mobil Glygyle 110	Optiflex A 100	Shell Trelia S 100	Tribol 800/100
Hydraulische HLP	ISO VG 32	29-35	Aral Vitam GP 32	STAROL Nr. 32	Energol HLP-HM 32	Hysyn AWS 32	RENOLIN B10	LAOMRA HLP 32	Mobil DTE 24	Hydro 32	Shell Tellus S 32	Tribol 943AW32
	ISO VG 460	414-506		BERUSYNTH 460 H1				Küblerol 4 UH1-460 N (CLP HC)	Mobil DTE FM 460	Optileb GT 460	Shell Cassida GL 460	Tribol (1810/460)
Food Grade Getriebeöle mit NSF-Freigabe Gear oil with NSF-approval (USDA-H1) CLP	ISO VG 220	198-242		BERUSYNTH 220 H1		Optileb GT 320 (PAO)		Küblersynth UH1 6-220 N (CLP HC)	Mobil DTE FM 220	Optileb GT 220	Shell Cassida GL 220	Tribol (1810/220)
	ISO VG 150	135-165		BERUSYNTH 150 H1		Optileb GT 220 (PAO)		Küblersynth UH1 6-150 N (CLP HC)	Mobil DTE FM 150	Optileb GT 150	Shell Cassida GL 150	
	ISO VG 68	61-75		BERUSYNTH 68 H1	Biohyd SES 68 (HLP)	Optileb GT 100 (PAO)		Küblersynth UH1 6-100 N (CLP HC)	Mobil DTE FM 68	Optileb GT 68	Shell Cassida HF 68	
	ISO VG 32	29-35		BERUSYNTH 68 H1		Optileb HY 32		Küblerol 4 UH1-32	Mobil DTE FM 32	Optileb HY 32	Shell Cassida HF 32	Tribol (1840/32)
Fetts / Fats	ISO VG 460	414-506					GEARMASTER ECO 460	Küblerol CA 2-460				
	ISO VG 220	198-242					GEARMASTER ECO 220	Küblersynth GEM 2-220				
	ISO VG 150	135-165					GEARMASTER ECO 150	Küblersynth CA 2-100				
	ISO VG 68	61-75					GEARMASTER ECO 68					
Fetts / Fats	ISO VG 460	414-506					LAGERMASTER 3000 Plus	Küblerplex BEM 41-132	Mobilux EP 2	Longline PD 2	Shell Retimax EPL 2	Tribol 3030/100
	ISO VG 220	198-242					URETHYN 160 (KP2/SP-20)	Küblerplex BE 31-222 (KP2/3N-10)	Mobilux EP 3	Oben UF 3	Shell Avania RL 3	
	ISO VG 150	135-165					GEARMASTER LI 400	Küblerplex GE 11-680	Mobilux EP04	Longline PD 00	Shell Natuelle Gear Fluol EP 150	Tribol Bo/Top 1418/220
	ISO VG 68	61-75					GERALYN 2	Küblersynth UH1 64-62	Mobilgrease FM 462	Oben UF 2	Shell Natuelle Gear Fluol EP 68	Tribol Bo/Top 1418/150

### Übersetzung

Transmission ratio

$$i = \frac{n_1}{n_2}$$

### Getriebetyp

Gearbox type

### Getriebegröße

Gearbox size

### Laterne

Bell housing

### Anordnung von Wellen an den Seiten D / E / F

Position of shafts on sides D / E / F

### Getriebeart

Gearbox model

### Spielarme Ausführung

Low-backlash version

S1 - < 10 Winkelminuten  
S2 - < 6 Winkelminuten

S1 - < 10 angular minutes  
S2 - < 6 angular minutes

**K 090 1,0 V L AB 0 A 1 a 2000 S1 /110**

### Wellenanordnung Abtriebsseite

Shaft position output side

### Lagerung

Bearing

### Motorflansch

Motor flange

### Einbaulage (unten liegende Seite)

Mounting orientation (downward-facing side)

### kleine Drehzahl

Low speed

$n_2 \text{ min}^{-1}$

### Schmierung

Lubrication

a - ISO VG 460  
b - ISO VG 220  
c - ISO VG 150  
d - ISO VG 68  
e - Einspritzschmierung  
spray lubrication  
f - Fließblett NLGI Kl. 00  
grease lubrication KL 00  
s - Sonderschmierung

### mit NSF/H1-Zulassung





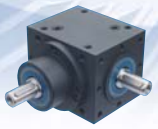





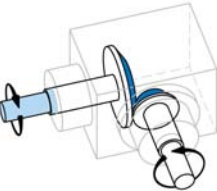

with NSF/H1-certification

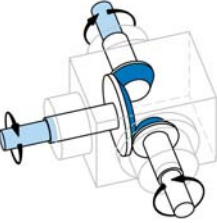
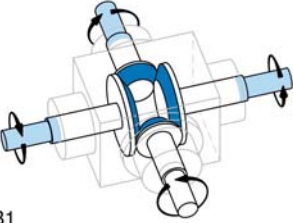

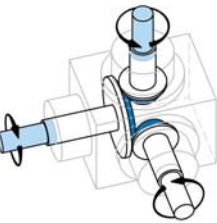
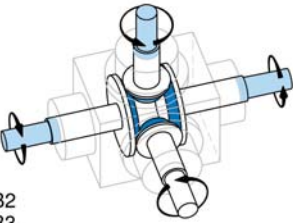

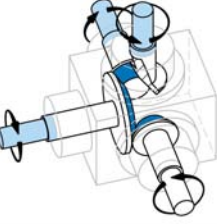
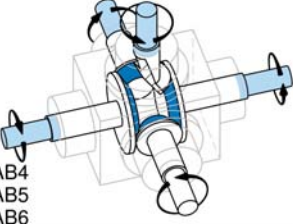



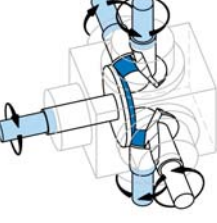
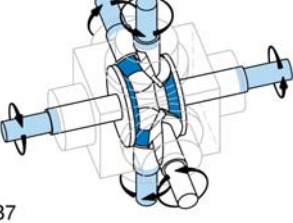



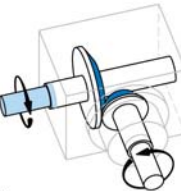
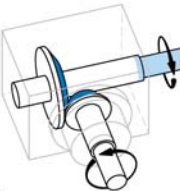
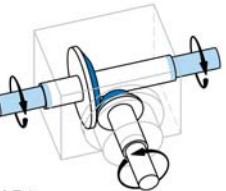

g - ISO VG 460  
h - ISO VG 220  
i - ISO VG 150  
j - ISO VG 68  
k - Einspritzschmierung  
spray lubrication  
l - Fließblett NLGI Kl. 00  
grease lubrication KI 00  
s - special lubrication

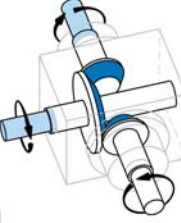
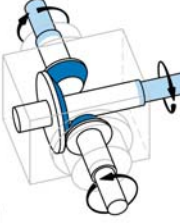
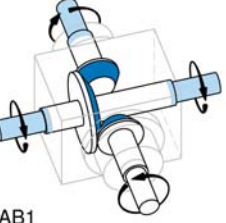

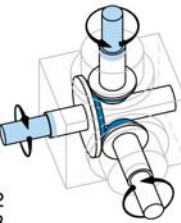
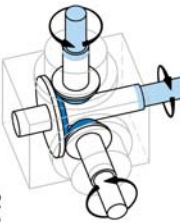
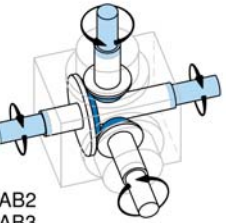
## Bauarten-Fliegend gelagerte Welle Models-solid shaft with single bearings

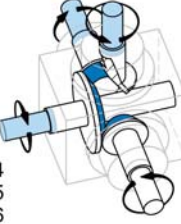
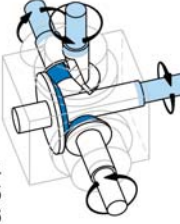
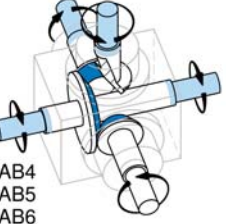
## Bauarten-Vollwelle Models-solid shaft

Typ F	A 	AB 
0 		
1 		
2 		
3 		
4 		
5 		
6 		
7 		

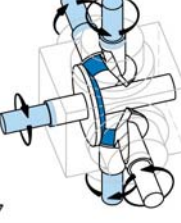
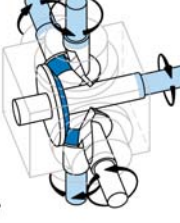
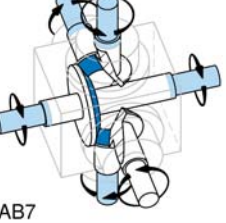
Typ V	A 	B 	AB 
0 			
1 			
2 			
3 			
4 			
5 			
6 			
7 			

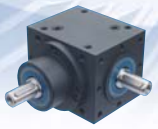

**Bauarten-Hohlwelle mit Schrumpfscheibe/Hohlwelle**  
**Models-hollow shaft with shrunken-on disc/hollow shaft**

**Bauarten-Ritzelwelle**  
**Models-pinion shaft**

Typ S / H	A	B	AB
0			
1			
2			
3			
4			
5			
6			
7			

Typ R	A	B	AB
0			
1			
2			
3			
4			
5			
6			
7			



## Typ F

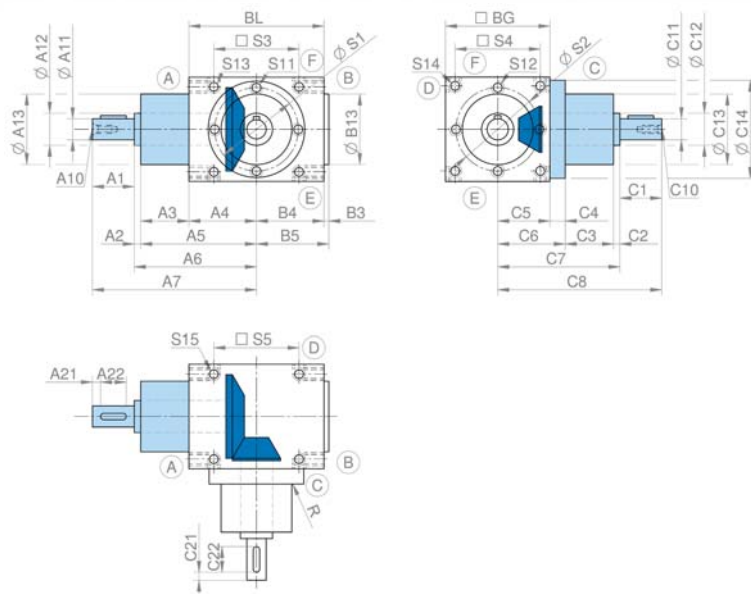
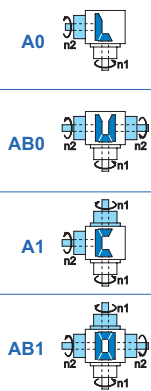

## Typ FL

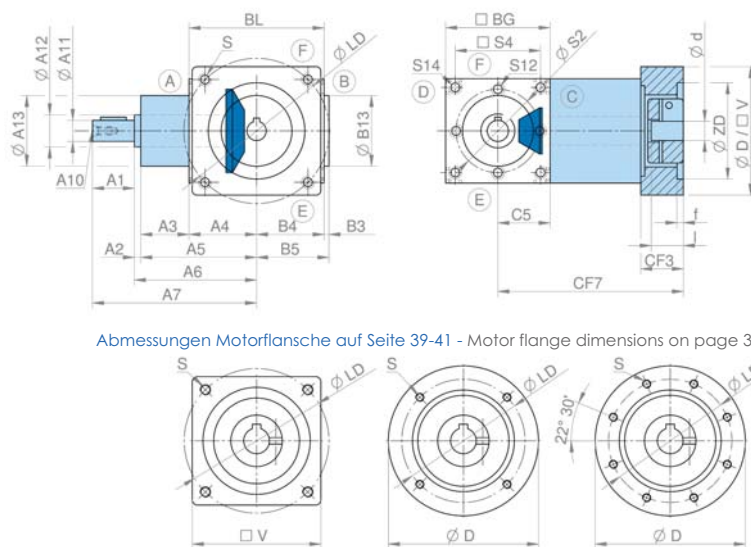
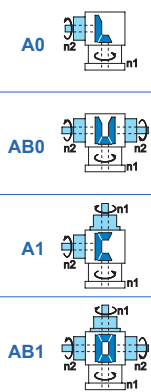

Abmessungen Motorflanze auf Seite 39-41 - Motor flange dimensions on page 39-41

## Fliegend gelagerte Vollwelle Solid shafts with single bearings

Größe Size	BG	BL	A1	A2	A3	B3	A4 B4	A5	B5	A6	A7	A10 DIN 332	A11	A12
065	65	84	26	2	30	2	42	72	44	74	100	DR M5	12 <sub>16</sub>	17
090	90	110	35	2	30	3	55	85	58	87	122	DR M6	18 <sub>16</sub>	25
120	120	144	45	2	43	3	72	115	75	117	162	DR M10	25 <sub>16</sub>	30
140	140	164	50	2	46	3	82	128	85	130	180	DR M12	32 <sub>16</sub>	40
160	160	190	60	2	55	3	95	150	98	152	212	DR M12	35 <sub>16</sub>	40
200	200	234	80	3	73	4	117	190	121	193	273	DR M16	42 <sub>16</sub>	55
260	260	300	110	5	115	4	150	265	154	270	380	DR M20	60 <sub>16</sub>	65

Größe Size	A13	B13	A21	A22	C1	C2	C3	C4	C5	C6	C7	C8	C10 DIN 332	C11
065	44 <sub>17</sub>	44 <sub>17</sub>	3	20	26	2	30	9,5	32,5	42	74	100	DR M5	12 <sub>16</sub>
090	60 <sub>17</sub>	60 <sub>17</sub>	3,5	28	35	2	30	10	45	55	87	122	DR M6	18 <sub>16</sub>
120	80 <sub>17</sub>	80 <sub>17</sub>	2,5	40	45	2	40	15	60	75	117	162	DR M10	25 <sub>16</sub>
140	95 <sub>17</sub>	90 <sub>17</sub>	2,5	45	50	2	45	13	70	83	130	180	DR M12	32 <sub>16</sub>
160	110 <sub>17</sub>	110 <sub>17</sub>	5	50	60	2	55	15	80	95	152	212	DR M12	35 <sub>16</sub>
200	120 <sub>17</sub>	120 <sub>17</sub>	5	70	80	3	70	20	100	120	193	273	DR M16	42 <sub>16</sub>
260	160 <sub>17</sub>	160 <sub>17</sub>	5	100	110	5	115	20	130	150	270	380	DR M20	60 <sub>16</sub>

Größe Size	C12	C13	C14	C21	C22	S1 S2	S3 S4	S5	S11	S12	S13 S14 S15	R
065	17	44 <sub>17</sub>	64,5 <sub>17</sub>	3	20	54	54	45	M6x9	M6x9	M6x12	1
090	25	60 <sub>17</sub>	85 <sub>17</sub>	3,5	28	75	70	70	M8x10	M8x9	M8x15	1
120	30	80 <sub>17</sub>	113 <sub>17</sub>	2,5	40	100	100	100	M10x15	M10x11	M10x18	1
140	40	95 <sub>17</sub>	130 <sub>17</sub>	2,5	45	115	110	110	M10x13	M10x11	M10x18	1
160	40	110 <sub>17</sub>	150 <sub>17</sub>	5	50	135	120	120	M12x15	M12x15	M12x24	2
200	55	120 <sub>17</sub>	190 <sub>17</sub>	5	70	175	160	160	M12x20	M12x17	M12x24	3
260	65	160 <sub>17</sub>	250 <sub>17</sub>	5	100	230	220	220	M16x20	M16x20	M16x32	5



## Typ V

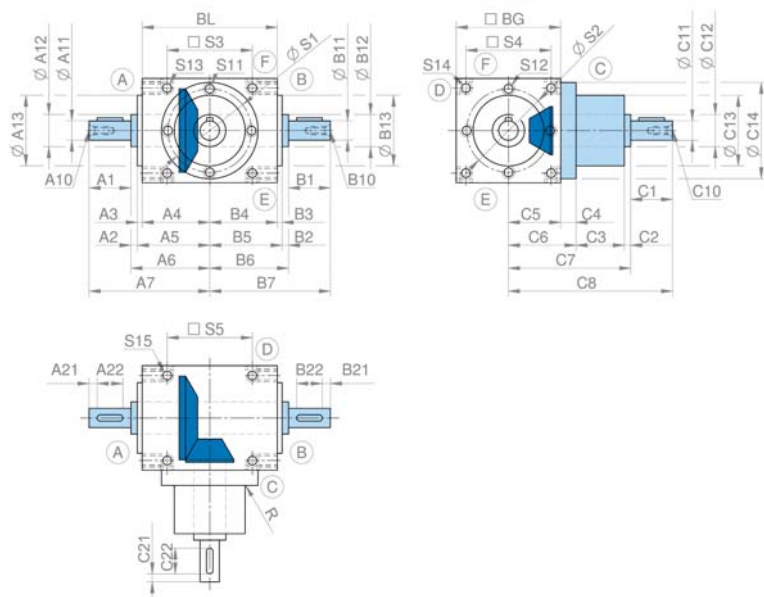
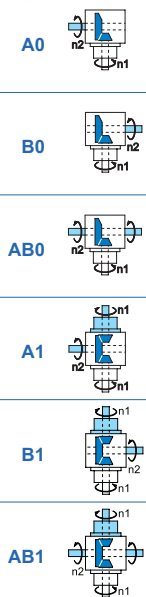

## Typ VL

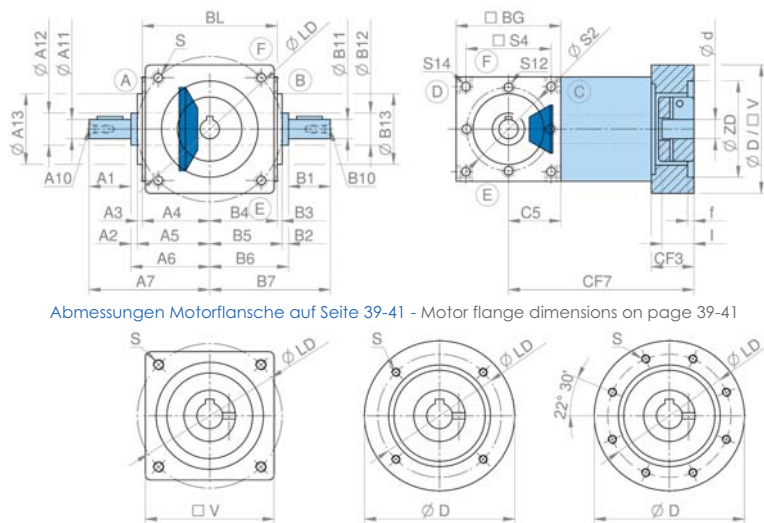
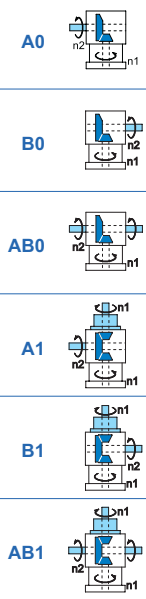

Abmessungen Motorflansche auf Seite 39-41 - Motor flange dimensions on page 39-41

## Vollwelle Solid shaft

Größe Size	BG	BL	A1 B1	A2 B2	A3 B3	A4 B4	A5 B5	A6 B6	A7 B7	A10 B10 DIN 332	A11 B11	A12 B12	A13 B13
065	65	84	26	2	2	42	44	46	72	DR M5	12 <sub>6</sub>	17	44 <sub>17</sub>
090	90	110	35	2	3	55	58	60	95	DR M6	18 <sub>6</sub>	25	60 <sub>17</sub>
120	120	144	45	2	3	72	75	77	122	DR M10	25 <sub>6</sub>	35	80 <sub>17</sub>
140	140	164	50	2	3	82	85	87	137	DR M12	32 <sub>6</sub>	40	90 <sub>17</sub>
160	160	190	60	2	3	95	98	100	160	DR M12	35 <sub>6</sub>	40	110 <sub>17</sub>
200	200	234	80	2	4	117	121	123	203	DR M16	42 <sub>6</sub>	55	120 <sub>17</sub>
260	260	300	110	3	4	150	154	158	268	DR M20	60 <sub>6</sub>	65	160 <sub>17</sub>

Größe Size	A21 B21	A22 B22	C1	C2	C3	C4	C5	C6	C7	C8	C10 DIN 332	C11	C12
065	3	20	26	2	30	9,5	32,5	42	74	100	DR M5	12 <sub>6</sub>	17
090	3,5	28	35	2	30	10	45	55	87	122	DR M6	18 <sub>6</sub>	25
120	2,5	40	45	2	40	15	60	75	117	162	DR M10	25 <sub>6</sub>	30
140	2,5	45	50	2	45	13	70	83	130	180	DR M12	32 <sub>6</sub>	40
160	5	50	60	2	55	15	80	95	152	212	DR M12	35 <sub>6</sub>	40
200	5	70	80	3	70	20	100	120	193	273	DR M16	42 <sub>6</sub>	55
260	5	100	110	5	115	20	130	150	270	380	DR M20	60 <sub>6</sub>	65

Größe Size	C13	C14	C21	C22	S1 S2	S3 S4	S5	S11	S12	S13 S14 S15	R
065	44 <sub>17</sub>	64,5 <sub>17</sub>	3	20	54	54	45	M6x9	M6x9	M6x12	1
090	60 <sub>17</sub>	85 <sub>17</sub>	3,5	28	75	70	70	M8x10	M8x9	M8x15	1
120	80 <sub>17</sub>	113 <sub>17</sub>	2,5	40	100	100	100	M10x15	M10x11	M10x18	1
140	95 <sub>17</sub>	130 <sub>17</sub>	2,5	45	115	110	110	M10x13	M10x11	M10x18	1
160	110 <sub>17</sub>	150 <sub>17</sub>	5	50	135	120	120	M12x15	M12x15	M12x24	2
200	120 <sub>17</sub>	190 <sub>17</sub>	5	70	175	160	160	M12x20	M12x17	M12x24	3
260	160 <sub>17</sub>	250 <sub>17</sub>	5	100	230	220	220	M16x20	M16x20	M16x32	5





## Typ H

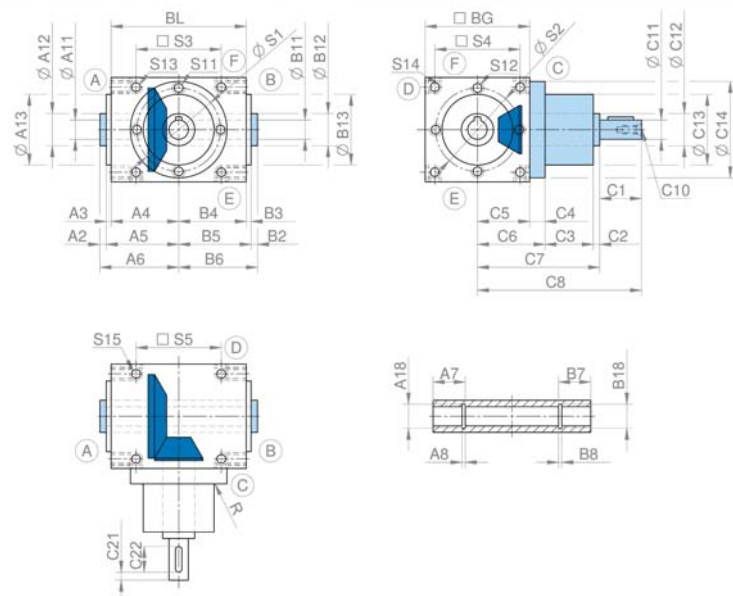
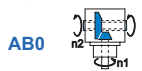

## Typ HL

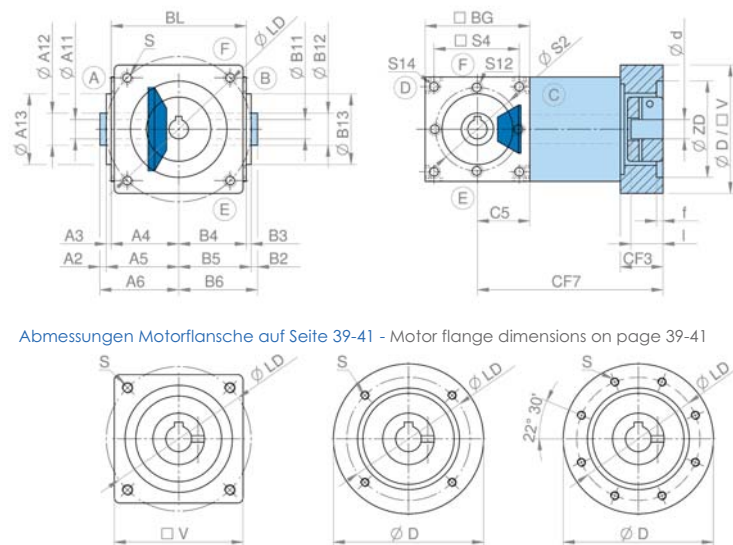
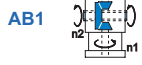

Abmessungen Motorflanze auf Seite 39-41 - Motor flange dimensions on page 39-41

## Hohlwelle Hollow shaft

Größe Size	BG	BL	A2 B2	A3 B3	A4 B4	A5 B5	A6 B6	A7 B7	A8 B8	A11 B11	A12 B12	A13 B13	A18 B18
065	65	84	2	2	42	44	46	-	-	12 <sup>H7</sup>	20	44 <sub>17</sub>	-
090	90	110	4	3	55	58	62	-	-	18 <sup>H7</sup>	30	60 <sub>17</sub>	-
120	120	144	5	3	72	75	80	-	-	25 <sup>H7</sup>	40	80 <sub>17</sub>	-
140	140	164	2	3	82	85	87	18	1,3	32 <sup>H7</sup>	45	90 <sub>17</sub>	33,7
160	160	190	5	3	95	98	103	18	1,6	35 <sup>H7</sup>	55	110 <sub>17</sub>	37
200	200	234	4	4	117	121	125	18	1,85	42 <sup>H7</sup>	70	120 <sub>17</sub>	44,5
260	260	300	6	4	150	154	160	20	2,15	60 <sup>H7</sup>	80	160 <sub>17</sub>	63

Größe Size	C1	C2	C3	C4	C5	C6	C7	C8	C10 DIN 332	C11	C12	C13
065	26	2	30	9,5	32,5	42	74	100	DR M5	12 <sub>16</sub>	17	44 <sub>17</sub>
090	35	2	30	10	45	55	87	122	DR M6	18 <sub>16</sub>	25	60 <sub>17</sub>
120	45	2	40	15	60	75	117	162	DR M10	25 <sub>16</sub>	30	80 <sub>17</sub>
140	50	2	45	13	70	83	130	180	DR M12	32 <sub>16</sub>	40	95 <sub>17</sub>
160	60	2	55	15	80	95	152	212	DR M12	35 <sub>16</sub>	40	110 <sub>17</sub>
200	80	3	70	20	100	120	193	273	DR M16	42 <sub>16</sub>	55	120 <sub>17</sub>
260	110	5	115	20	130	150	270	380	DR M20	60 <sub>16</sub>	65	160 <sub>17</sub>

Größe Size	C14	C21	C22	S1 S2	S3 S4	S5	S11	S12	S13 S14 S15	R
065	64,5 <sub>17</sub>	3	20	54	54	45	M6x9	M6x9	M6x12	1
090	85 <sub>17</sub>	3,5	28	75	70	70	M8x10	M8x9	M8x15	1
120	113 <sub>17</sub>	2,5	40	100	100	100	M10x15	M10x11	M10x18	1
140	130 <sub>17</sub>	2,5	45	115	110	110	M10x13	M10x11	M10x18	1
160	150 <sub>17</sub>	5	50	135	120	120	M12x15	M12x15	M12x24	2
200	190 <sub>17</sub>	5	70	175	160	160	M12x20	M12x17	M12x24	3
260	250 <sub>17</sub>	5	100	230	220	220	M16x20	M16x20	M16x32	5



## Typ S

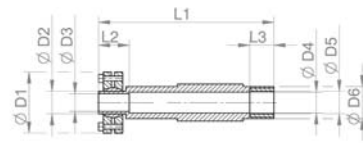
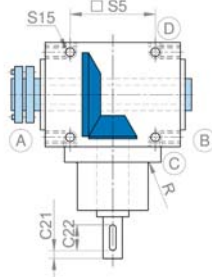
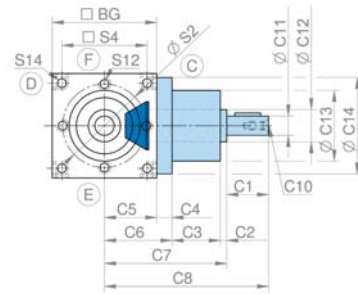
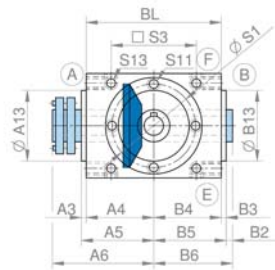
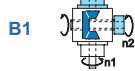
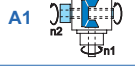
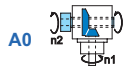

## Typ SL

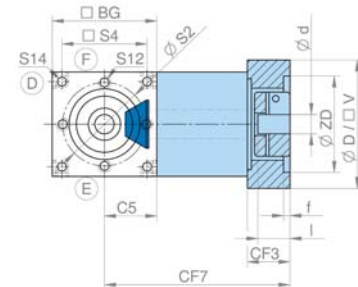
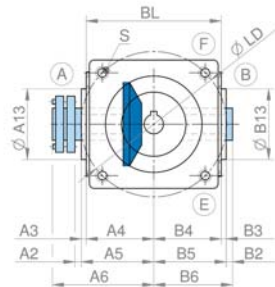
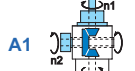
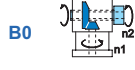
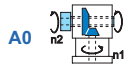

Abmessungen Motorflansche auf Seite 39-41 - Motor flange dimensions on page 39-41

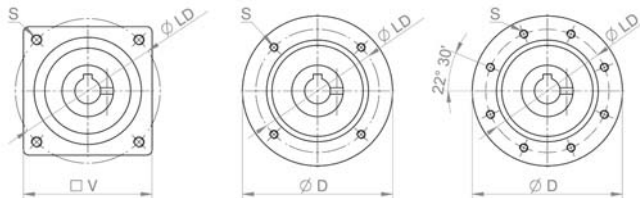

## Hohlwelle mit Schrumpfscheibe Hollow shaft with shrunk-on disk

Größe Size	BG	BL	B2	A3 B3	A4 B4	A5 B5	A6	B6	A13 B13	C1	C2	C3	C4	C5	C6
065	65	84	2	2	42	44	63	46	44 <sub>17</sub>	26	2	30	9,5	32,5	42
090	90	110	4	3	55	58	86	62	60 <sub>17</sub>	35	2	30	10	45	55
120	120	144	5	3	72	75	107	80	80 <sub>17</sub>	45	2	40	15	60	75
140	140	164	2	3	82	85	122	87	90 <sub>17</sub>	50	2	45	13	70	83
160	160	190	5	3	95	98	135	103	110 <sub>17</sub>	60	2	55	15	80	95
200	200	234	4	4	117	121	162	125	120 <sub>17</sub>	80	3	70	20	100	120
260	260	300	6	4	150	154	200	160	160 <sub>17</sub>	110	5	115	20	130	150

Größe Size	C7	C8	C10 DIN 332	C11	C12	C13	C14	C21	C22	D1	D2	D3	D4	D5
065	74	100	DR M5	12 <sub>j6</sub>	17	44 <sub>17</sub>	64,5 <sub>17</sub>	3	20	38	14 <sub>h7</sub>	12 <sup>H6</sup> <sub>j6</sub>	12,2	14 <sup>H7</sup> <sub>h6</sub>
090	87	122	DR M6	18 <sub>j6</sub>	25	60 <sub>17</sub>	85 <sub>17</sub>	3,5	28	50	24 <sub>h7</sub>	18 <sup>H6</sup> <sub>j6</sub>	19	20 <sup>H7</sup> <sub>h6</sub>
120	117	162	DR M10	25 <sub>j6</sub>	30	80 <sub>17</sub>	113 <sub>17</sub>	2,5	40	60	30 <sub>h7</sub>	25 <sup>H6</sup> <sub>j6</sub>	26	27 <sup>H7</sup> <sub>h6</sub>
140	130	180	DR M12	32 <sub>j6</sub>	40	95 <sub>17</sub>	130 <sub>17</sub>	2,5	45	80	44 <sub>h7</sub>	32 <sup>H6</sup> <sub>j6</sub>	33	34 <sup>H7</sup> <sub>h6</sub>
160	152	212	DR M12	35 <sub>j6</sub>	40	110 <sub>17</sub>	150 <sub>17</sub>	5	50	80	44 <sub>h7</sub>	35 <sup>H6</sup> <sub>j6</sub>	36	37 <sup>H7</sup> <sub>h6</sub>
200	193	273	DR M16	42 <sub>j6</sub>	55	120 <sub>17</sub>	190 <sub>17</sub>	5	70	100	55 <sub>h7</sub>	42 <sup>H6</sup> <sub>j6</sub>	43	44 <sup>H7</sup> <sub>h6</sub>
260	270	380	DR M20	60 <sub>j6</sub>	65	160 <sub>17</sub>	250 <sub>17</sub>	5	100	138	75 <sub>h7</sub>	60 <sup>H6</sup> <sub>j6</sub>	61	62 <sup>H7</sup> <sub>h6</sub>

Größe Size	D6	L1	L2	L3	S1 S2	S3 S4	S5	S11	S12	S13 S14 S15	R
065	20	109	18	15	54	54	45	M6x9	M6x9	M6x12	1
090	30	148	26	20	75	70	70	M8x10	M8x9	M8x15	1
120	40	187	28	20	100	100	100	M10x15	M10x11	M10x18	1
140	45	209	32	30	115	110	110	M10x13	M10x11	M10x18	1
160	55	237	32	30	135	120	120	M12x15	M12x15	M12x24	2
200	70	287	37	35	175	160	160	M12x20	M12x17	M12x24	3
260	80	360	41	40	230	220	220	M16x20	M16x20	M16x32	5



## Typ R

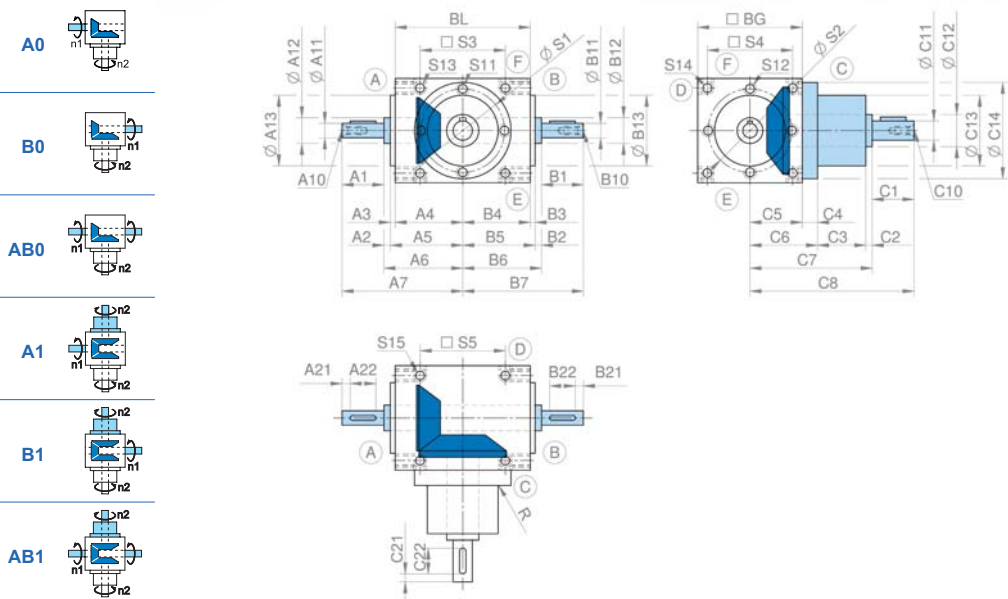

## Typ RL

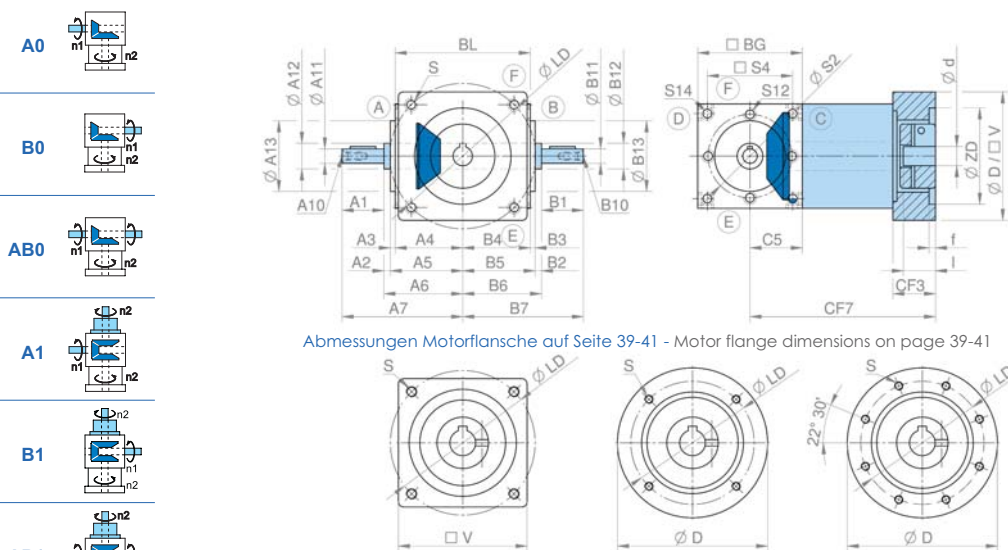

Abmessungen Motorflansche auf Seite 39-41 - Motor flange dimensions on page 39-41

## Ritzelwelle Pinion shaft

Größe Size	BG	BL	A1 B1	A2 B2	A3 B3	A4 B4	A5 B5	A6 B6	A7 B7	A10 B10 DIN 332	A11 B11	A12 B12	A13 B13
090	90	110	35	2	3	55	58	60	95	DR M5	14 <sub>j6</sub>	15	60 <sub>f7</sub>
120	120	144	45	2	3	72	75	77	122	DR M5	16 <sub>j6</sub>	20	80 <sub>f7</sub>
140	140	164	50	2	3	82	85	87	137	DR M6	20 <sub>j6</sub>	25	90 <sub>f7</sub>
160	160	190	60	2	3	95	98	100	160	DR M10	25 <sub>j6</sub>	30	110 <sub>f7</sub>
200	200	234	80	2	4	117	121	123	203	DR M12	35 <sub>j6</sub>	40	120 <sub>f7</sub>
260	260	300	90	3	4	150	154	158	248	DR M16	45 <sub>j6</sub>	60	160 <sub>f7</sub>

Größe Size	A21 B21	A22 B22	C1	C2	C3	C4	C5	C6	C7	C8	C10 DIN 332	C11	C12
090	3,5	28	35	2	30	10	45	55	87	122	DR M6	18 <sub>j6</sub>	25
120	4,5	36	45	2	40	15	60	75	117	162	DR M10	25 <sub>j6</sub>	30
140	5	40	50	2	45	13	70	83	130	180	DR M12	32 <sub>j6</sub>	40
160	5	50	60	2	55	15	80	95	152	212	DR M12	35 <sub>j6</sub>	40
200	5	70	80	3	70	20	100	120	193	273	DR M16	42 <sub>j6</sub>	55
260	5	80	110	5	115	20	130	150	270	380	DR M20	60 <sub>j6</sub>	65

Größe Size	C13	C14	C21	C22	S1 S2	S3 S4	S5	S11	S12	S13 S14 S15	R
090	60 <sub>f7</sub>	85 <sub>f7</sub>	3,5	28	75	70	70	M8x10	M8x9	M8x15	1
120	80 <sub>f7</sub>	113 <sub>f7</sub>	2,5	40	100	100	100	M10x15	M10x11	M10x18	1
140	95 <sub>f7</sub>	130 <sub>f7</sub>	2,5	45	115	110	110	M10x13	M10x11	M10x18	1
160	110 <sub>f7</sub>	150 <sub>f7</sub>	5	50	135	120	120	M12x15	M12x15	M12x24	2
200	120 <sub>f7</sub>	190 <sub>f7</sub>	5	70	175	160	160	M12x20	M12x17	M12x24	3
260	160 <sub>f7</sub>	250 <sub>f7</sub>	5	100	230	220	220	M16x20	M16x20	M16x32	5

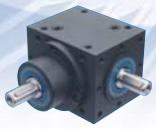

# Übertragbare Kupplungsdrehmomente Transferrable coupling torque

# Flansche für IEC-Normmotoren Flange for IEC-standard motors

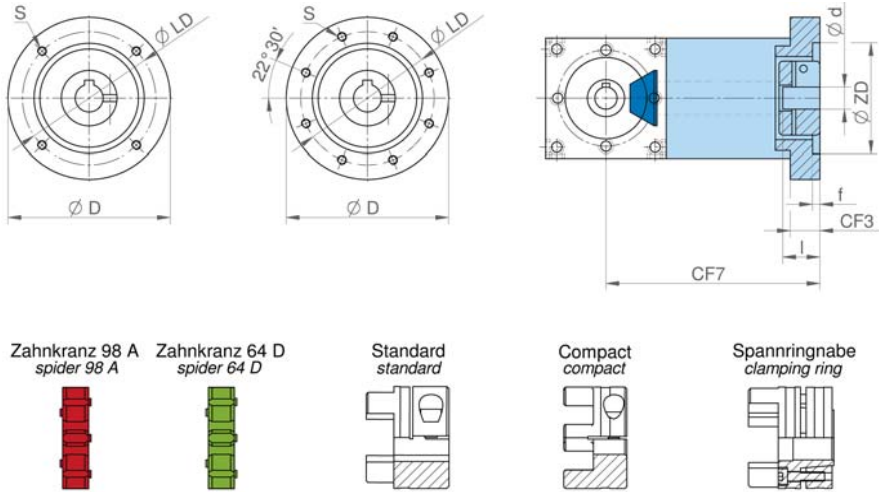

Maße CF3 und CF7 nur für angegebene Kupplung / dimensions CF3 and CF7 only for indicated coupling  
 \*Größere Drehmomente mit Kupplungsstern 68 Shore D / Larger torques with coupling speeder 68 Shore D

Größe size	Zahnkranz / spider				Standard-Kupplung / Standard-coupling, T <sub>KN</sub> [Nm]																			
	98 A		64 D		Ø10	Ø11	Ø14	Ø18	Ø19	Ø20	Ø24	Ø25	Ø28	Ø30	Ø32	Ø35	Ø38	Ø40	Ø42	Ø45	Ø48	Ø50	Ø55	
14	13	25	16	32	5,5	5,6	6,1																	
19	17	34	21	42	27	27	29	32	32	34	32													
24	60	120	75	150	34	35	36	39	40	41	43	45	46											
28	160	320	200	400			80	84	85	87	91	92	97	99	102	105	109							
38	325	650	405	810				97	98	99	104	105	109	112	113	118	122	123	126	130				
42	450	900	560	1120							232	244	246	255	260	266	274	283	288	294	301	309		
48	525	1050	655	1310									393	405	413	421	434	445	454	462	473	486	494	514
55	685	1370	825	1650												473	486	498	507	514	526	539	547	567

  

Größe size	Zahnkranz / spider				Compact-Kupplung / Compact-coupling, T <sub>KNC</sub> [Nm]																			
	98 A		64 D		Ø10	Ø11	Ø14	Ø18	Ø19	Ø20	Ø24	Ø25	Ø28	Ø30	Ø32	Ø35	Ø38	Ø40	Ø42	Ø45	Ø48	Ø50	Ø55	
14	13	25	16	32	8,5	8,8	5,8																	
19	17	34	21	42	26	26	28	31	32	32	25													
24	60	120	75	150	21	23	30	38	40	42	51	53	59	63	68									
28	160	320	200	400			54	70	74	78	93	97	109	116	124	136								
38	325	650	405	810				11	117	123	148	154	173	185	197	216	234	247	259	278				

Größe size	Zahnkranz / spider				Kupplung mit Spannringnabe / Coupling with clamping ring, T <sub>SN</sub> [Nm]																			
	98 A		64 D		Ø10	Ø11	Ø14	Ø18	Ø19	Ø20	Ø24	Ø25	Ø28	Ø30	Ø32	Ø35	Ø38	Ø40	Ø42	Ø45	Ø48	Ø50	Ø55	
14	13	25	16	32	14	15	23																	
19	17	34	21	42	41	45	62	67	83	90	34	30	32											
24	60	120	75	150		48	67	72	90	97	112	120	143											
28	160	320	200	400					154	189	188	237	250	280	307	310	353	389						
38	325	650	405	810						269	337	356	398	436	442	501	533	572	615	644				
42	450	900	560	1120								399	445	506	470	566	581	647	630	728	836	858		
48	525	1050	655	1310										650	685	809	841	926	916	1042	1181	1125	1311	
55	685	1370	825	1650												918	954	1052	1040	1185	1220	1318	1359	

Getriebe Gearbox	Flansch Flange Nr.	Motor Motor	d x l	Befestigungsflansch / Fastening flange								Kupplung / Coupling				
				IEC / DIN	ZD	LD	D	S	f	CF3	CF7	Größe size	T <sub>KN</sub> Nm	T <sub>KNC</sub> Nm	T <sub>SN</sub> Nm	
065	101	56	9 x 20	C105 / B14	70	85	105	4 x Ø7	3	15	106	14 Compact	5,3	6,1	12,5	
	102	63	11 x 23	A140 / B5	95	115	140	4 x M8	5				5,6			
	103	71	14 x 30	C105 / B14	70	85	105	4 x Ø7	3	24	115		6,1	5,8		
	104			A160 / B5	110	130	160	4 x M8								
090	201	63	11 x 23	C120 / B14	80	100	120	4 x Ø7	3	16	137	19 Compact	17*	17*	17*	
	202			A140 / B5	95	115	140	4 x M8	5							
	203	71	14 x 30	C140 / B14				4 x Ø9								
	204			A160 / B5	110	130	160	4 x M8								
	205			C120 / B14	80	100	120	4 x Ø7	3							
	206	80	19 x 40	C160 / B14	110	130	160	4 x Ø9								
	207			A200 / B5	130	165	200	4 x M10								
	208	90S / 90L	24 x 50	C140 / B14	95	115	140	4 x Ø9	5							
	209															
	210	100L / 112M	28 x 60	C160 / B14	110	130	160	4 x Ø9	5							35
120	301	63	11 x 23	A140 / B5	95	115	140	4 x M8	5	20	171	24 Compact	43	59	60	
	302	71	14 x 30	A160 / B5	110	130	160	4 x M8					35	23		
	303	80	19 x 40	C160 / B14				4 x Ø9					36	30		
	304			A200 / B5	130	165	200	4 x M10					40	40		
	305	90S / 90L	24 x 50	C160 / B14	110	130	160						43	51		
	306			A200 / B5	130	165	200	4 x M10								
	307			C160 / B14	110	130	160	4 x Ø9								
	308	100L / 112M	28 x 60	C200 / B14	130	165	200	4 x Ø11					46	59		
	309			A250 / B5	180	215	250	4 x M12								
	140	401	63	11 x 23	A140 / B5	95	115	140					4 x M8	5	22	220
402		71	14 x 30	A160 / B5	110	130	160	4 x M8	85							
403		80	19 x 40	A200 / B5	130	165	200	4 x M10	91							
404		90S / 90L	24 x 50	A200 / B5	130	165	200	4 x M10	97							
405		100L / 112M	28 x 60	C200 / B14	130	165	200	4 x Ø11	109							
406				A250 / B5	180	215	250									
407		132S / 132M	38 x 80	A300 / B5	230	265	300	4 x M12	50	247,5						
160	501	80	19 x 40						5	22	242	28 Standard	85	160		
	502	90 S / 90 L	24 x 50	A200 / B5	130	165	200	4 x M10					91			
	503	100L / 112M	28 x 60	A250 / B5	180	215	250	4 x M12					97			
	504	132S / 132M	38 x 80	A300 / B5	230	265	300						109			
200	601	100L / 112M	28 x 60	A250 / B5	180	215	250	4 x M12	5	28	333	48 Standard	405	525		
	602	132S / 132M	38 x 80	A300 / B5	230	265	300						32		336,5	445
	603	160M / 160L	42 x 110													
	604	180M / 180L	48 x 110	A350 / B5	250	300	350	4 x M16					6		33	362,5
260	801	132S / 132M	38 x 80	A300 / B5	230	265	300	4 x M12	7	28	430	55 Standard	498	685		
	802	160M / 160L	42 x 110													
	803	180M / 180L	48 x 110	A350 / B5	250	300	350	4 x M16					47		449	539
	804	200L	55 x 110	A400 / B5	300	350	400	4 x M16								
	805	225S / 225M	60 x 140	A450 / B5	350	400	450	8 x M16					77		479	587

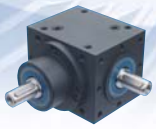

# Flansche für Servo Motoren

# Flanges for servo motors

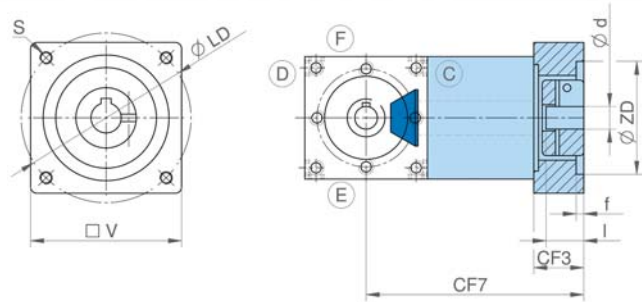

Maße CF3 und CF7 nur für angegebene Kupplung / dimensions CF3 and CF7 only for indicated coupling

\* Größere Drehmomente mit Kupplungsstern 68 Shore D / Larger torques with coupling speeder 68 Shore D

Getriebe Gearbox	Flansch Flange Nr.	Motor / Motor		Befestigungsflansch / Fastening flange						Kupplung / Coupling												
		d	l	ZD	LD	V	S	f	CF3	CF7	Größe size	T <sub>KN</sub> Nm	T <sub>KNC</sub> Nm	T <sub>SN</sub> Nm								
065	121	9	23	70 <sup>H7</sup>	85	75	M6	4	15	106	14 Compact	5,3	6,1	12,5								
	122			40 <sup>H7</sup>	63	65	M4															
	123																					
	124	11	23	60 <sup>H7</sup>	75	70	M5															
	125				90	80																
	126			80 <sup>H7</sup>	100	90	M6															
	127	14	30	60 <sup>H7</sup>	75	70	M5															
	128				90	80	M6															
	129			50 <sup>H7</sup>	95	90	M6															
	130			80 <sup>H7</sup>	100	90	M8															
	131			95 <sup>H7</sup>	115	100	M8															
	132																					
090	221	9	23	70 <sup>H7</sup>	85	95	M6	5	16	137	19 Compact	17*	17*	17*								
	222	11	23	80 <sup>H7</sup>	100																	
	223	14	35	95 <sup>H7</sup>	115	100	M8															
	224	19	40	60 <sup>H7</sup>	75	90	M6															
	225				90	90	M5															
	226			50 <sup>H7</sup>	95	90	M6															
	227			80 <sup>H7</sup>	100																	
	228			95 <sup>H7</sup>	115	100	M8															
	229				105																	
	230			130	115																	
	231	100 <sup>H7</sup>		145	120																	
	232			165	140	M10																
	233			110 <sup>H7</sup>	130	130	M8															
	234																					
	120	321	11	23	80 <sup>H7</sup>	100	125								M6	5	20	171	24 Compact	43	51	60
		322	14	35	95 <sup>H7</sup>	115	125								M8							
323		19	45	110 <sup>H7</sup>	130	130	M8															
324		24	50	60 <sup>H7</sup>	75		M6															
325					90		M5															
326				50 <sup>H7</sup>	95	120	M6															
327				80 <sup>H7</sup>	100																	
328				95 <sup>H7</sup>	115		M8															
329				95 <sup>H7</sup>	130		M8															

Getriebe Gearbox	Flansch Flange Nr.	Motor / Motor		Befestigungsflansch / Fastening flange						Kupplung / Coupling													
		d	l	ZD	LD	V	S	f	CF3	CF7	Größe size	T <sub>KN</sub> Nm	T <sub>KNC</sub> Nm	T <sub>SN</sub> Nm									
120	330	24	50	110 <sup>H7</sup>	130	120	M8	5	20	171	24 Compact	43	51	60									
	331				145																		
	332			130 <sup>H7</sup>	165	140	M10																
	333																						
	334				28	60									46	197	46	59					
140	421	19	45	110 <sup>H7</sup>	130	130	M8	6	22	220	28 Standard	102	160										
	422	24	50	110 <sup>H7</sup>	130	130	M8																
	423	28	60	130 <sup>H7</sup>	165	140	M10																
	424	32	60	80 <sup>H7</sup>	100		M6																
	425			95 <sup>H7</sup>	115																		
	426			130	140									M8									
	427																						
	428			110 <sup>H7</sup>	60	145								M10									
	429					165								M8									
	430	180 <sup>H7</sup>	215			190	M12																
	431	38	80	230 <sup>H7</sup>	265	240																	
	432																						
	433																						
	434						49,5							247,5	109								
	435																						
	160	521	32	60	80 <sup>H7</sup>	100	160							M6	6	22	242	28 Standard	102	160			
		522			95 <sup>H7</sup>	115								M8									
		523			110 <sup>H7</sup>	60								130							160	M10	
524																							
525																							
526		145							M8														
527																							
528		130 <sup>H7</sup>			60	165		190	M10														
529																							
530										180 <sup>H7</sup>	215	190	M12										
531		38			80	230 <sup>H7</sup>		265	240														
532																							
533																							
534										49,5	269,5	109											
200		621			32	60		110 <sup>H7</sup>	130	200	M8	6	28	353							55 Standard	473	685
		622							165		M10												
	623	130 <sup>H7</sup>	215																				
	624																						
	625	180 <sup>H7</sup>	60	215			240	M12															
	626																						
	627																						
	628	38	80	230 <sup>H7</sup>			265	240															
	629																						
	630																						
	631	42	110	250 <sup>H7</sup>			300	260	M16														
	632																						
633																							
260	821	32	58	130 <sup>H7</sup>	165	155	12	6	28	430	55 Standard	473	685										
	822	38	80	180 <sup>H7</sup>	215	192	13																
	823	48	82																				
	824	42	110	250 <sup>H7</sup>	300	260	16																
	825	48																					
	826	55		300 <sup>H7</sup>	350	314	13																
	827	60	140	300 <sup>H7</sup>	400	400	15																
														32	434	498							
														28	430	514							
														47	449	539							
							77	479	567														
									587														

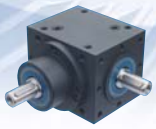

Detaillierte Berechnungen aller Getriebekomponenten in Kombination mit Praxiserfahrung, sowie umfangreichen Versuchsreihen auf Leistungs- und Dauerfestigkeitsprüfständen ermöglichen das hohe Leistungsvermögen und die Sicherheit der arcus Getriebe. Eine kontinuierlich hohe Qualität wird durch die Sorgfalt und das Fachwissen unserer Mitarbeiter und Lieferanten garantiert.

Die Überprüfung der Materialgüte und die Maßhaltigkeit aller Getriebebauteile erfolgt für jede Charge in Stichproben. Bei der Montage werden die Zahnräder in ihrer Position exakt vermessen und zusätzlich einer Kontrolle des Verzahnungstragbildes

gaben im Katalog / Internet unumgänglich. Das Öffnen der Getriebegehäuse und das Entfernen von Typenschildern führen zu Garantieverlust.

Unser Ziel ist, Ihre Konstruktionsaufgabe in ein für Sie optimal gestaltetes Getriebe umzusetzen. Daher bieten wir Ihnen haftungsfrei jegliche Unterstützung durch unser kompetentes Team an. So ist arcus Getriebetechnik der ideale Partner, wenn es um Kegelradgetriebe made in germany geht.

**arcus Getriebe - Qualität und Innovation, die überzeugen.**



unterzogen. Vor der Auslieferung werden wichtige Anschlussmaße und auf Anfrage Schallemissionen, Temperaturen, Losbrech- und Beharrungsmomente aufgenommen.

Bei Wareneingang prüfen Sie bitte die gelieferten Getriebe auf eventuelle Transportschäden und melden diese umgehend der Spedition. Zur Erfüllung von Gewährleistungsansprüchen ist die Einhaltung der Bedienungsanleitung und der technischen An-

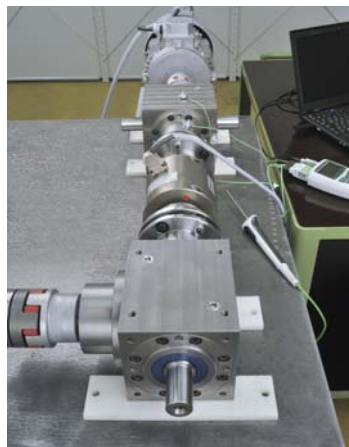

Detailed calculations of all gearbox components in combination with practical experience, comprehensive test series on performance and endurance strength test beds enable high efficiency and the safety of the arcus gearboxes. A continuously high quality is guaranteed through the diligence and expertise of our employees and suppliers.

The inspection of the material quality and the dimensional stability of all gearbox components takes place for each batch in samples. During assembly, the gears are measured exactly in their position and are also subjected to an inspection of the gearing contact pattern. Before delivery, important connecting dimensions and upon request sound emissions, temperatures, breakaway and persistence torque are recorded.

During goods receipt, please inspect the delivered gearboxes for potential transport damage and immediately report any damage to the shipping company. In order to meet the warranty claims, compliance with the operating instructions and the technical specifications in the catalog / internet is essential. The opening of the gearbox housing and the removal of name plates lead to loss of warranty. Our goal is to convert your design job into a gearbox optimally configured for you. We thus offer you – free of obligation – all support from our expert team.



arcus Getriebetechnik is thus the ideal partner for bevel gears that are Made in Germany.

arcus gearboxes – convincing quality and innovation. All information was thoroughly checked and matches the technical state of the print date. Subject to change without notice. Our "Standard Terms and Conditions" apply.





Alle Angaben wurden sorgfältig geprüft und entsprechen dem technischen Stand des Druckdatums. Änderungen vorbehalten.  
Es gelten unsere Allgemeinen Geschäftsbedingungen.  
Bitte informieren Sie sich auf unserer Internetseite über Aktualisierungen, Neuheiten oder Änderungen.

[www.arcus-getriebe.de](http://www.arcus-getriebe.de)

**arcus**   
GETRIEBETECHNIK

arcus Getriebetechnik  
Dipl. Ing. Dammenhayn  
Rissener Straße 140  
22880 Wedel

Telefon: +49 (0) 4103 / 90 006 - 20  
Telefax: +49 (0) 4103 / 90 006 - 26  
Mobil: +49 (0) 172 / 460 4500  
E-Mail: [gd@arcus-getriebe.de](mailto:gd@arcus-getriebe.de)  
[www.arcus-getriebe.de](http://www.arcus-getriebe.de)

08/2008